

PREMIUM BESPOKE TIMBER WINDOWS & DOORS

QUALITY CRAFTSMANSHIP



TYPES OF WOOD

PINE FINGERJOINTED - AVAILABLE

SOLID PINE - AVAILABLE

MERANTI - AVAILABLE

OAK - AVAILABLE

SAPELE - AVAILABLE

ACCOYA - AVAILABLE

LARCH - AVAILABLE

RED GRANDIS - AVAILABLE AFTER CONFIRMATION

FINGERJOINTED TIMBER AVAILABLE IN LENGTHS UP TO 6M

SOLID PIECES OF WOOD AVAILABLE IN LENGTHS UP TO 2,8M

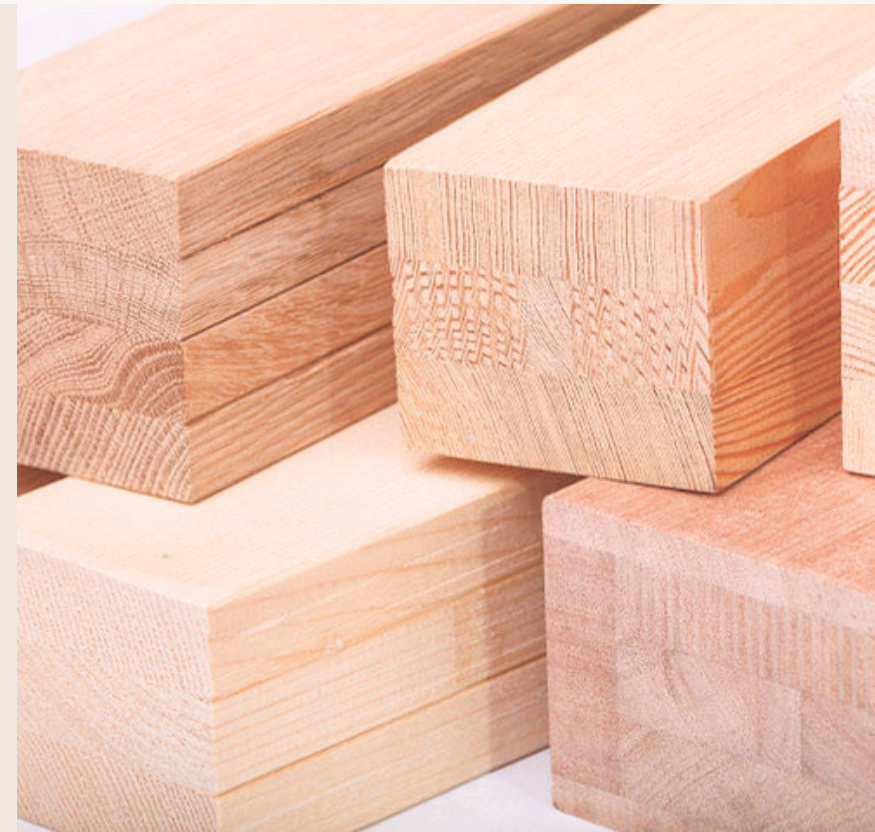

SOLID PAINT COLOUR CHARTS

RAL CLASSIC

FARROW & BALL

LITTLE GREENE

NCS - NATURAL COLOUR SYSTEM

BRITISH STANDARD

OTHER PALLETS AVAILABLE ON REQUEST



STAINS FROM TEKNOS

	PINE	MERANTI	OAK		PINE	MERANTI	OAK
PINIA				KASZTAN			
STARA SOSNA				SIPO			
CYPRYS				FRAMIRE			
IROKO				SAPELLI			
DAB				AFROMOZJA			
CALVADOS				WISNIA			
ORZECH				WENGE			
KEMPAS				ACAJOU			

AVAILABLE COLOUR OPTIONS

SINGLE SOLID



SINGLE STAIN



DUAL COLOUR SOLID

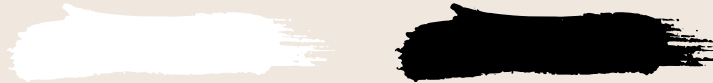

DUAL COLOUR STAIN



CLEAR LACQUER FINISH/TRANSPARENT (NATURAL TIMBER LOOK)

GLOSS LEVELS FOR SOLID PAINTS

MATT: AVERAGE 15 DEGREES (13-18 DEGREES)





















SEMI MATT (OUR STANDARD): AVERAGE 20 DEGREES (17-23 DEGREES)

GLOSS: AVERAGE 30 DEGREES (27-33 DEGREES)

HIGH GLOSS: AVERAGE 60 DEGREES (57-63 DEGREES)

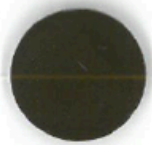
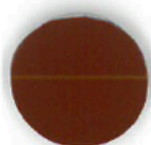
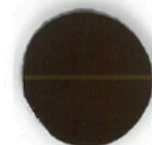
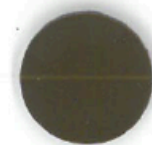

AVAILABLE SILICONE COLOURS

 <p>biały white белый RAL 9016</p>	 <p>czarny black чёрный RAL 9005</p>	 <p>bezbardwy clear бесцветный</p>	 <p>sosna pine сосна RAL 1011</p>	 <p>kremowy cream кремовый RAL 1013</p>	 <p>dąb bielony bleached oak беленый дуб RAL 1019</p>
 <p>szary antracytowy anthracite grey серый антрацит RAL 7016</p>	 <p>szary grey серый RAL 7037</p>	 <p>szary okienny window grey серый оконный RAL 7040</p>	 <p>dąb winchester winchester oak дуб винчестер RAL 8001(1)</p>	 <p>dąb jasny light oak дуб светлый RAL 8001(2)</p>	 <p>dąb rustykalny rustical oak дуб деревенский RAL 8003</p>
 <p>bursztynowy amber янтарный RAL 8007</p>	 <p>brąz ciemny dark brown коричневый тёмный RAL 8011</p>	 <p>brąz czekoladowy chocolate brown коричневый шоколадный RAL 8017(1)</p>	 <p>orzech laskowy hazelnut лесной орех RAL 8017(2)</p>	 <p>brąz średni medium brown коричневый средний RAL 8025</p>	 <p>zielony świerk green spruce зелёная ель RAL 6020 *</p>
 <p>szary jedwabisty silk-grey шелковисто-серый RAL 7038 *</p>	 <p>teak teak тиковое дерево RAL 8002 *</p>	 <p>sepia sepia сепия RAL 8014 *</p>	 <p>mahoń mahogany красное дерево RAL 8015 *</p>	 <p>palisander rosewood палисандр RAL 8016 *</p>	 <p>brąz terra terra brown коричневый землистый RAL 8028 *</p>

TYPES OF BARS

STICK ON GLAZING BARS

OVOLO - SIZES 17/20/22/26 MM

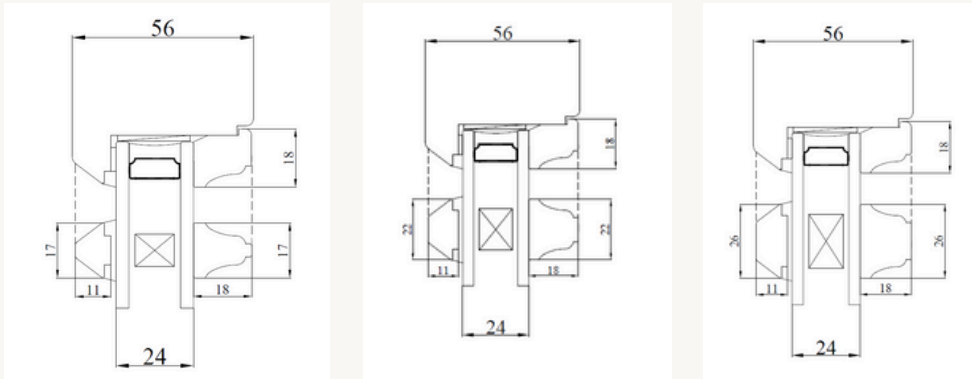

SQUARE- SIZES 17/20/22/26 MM

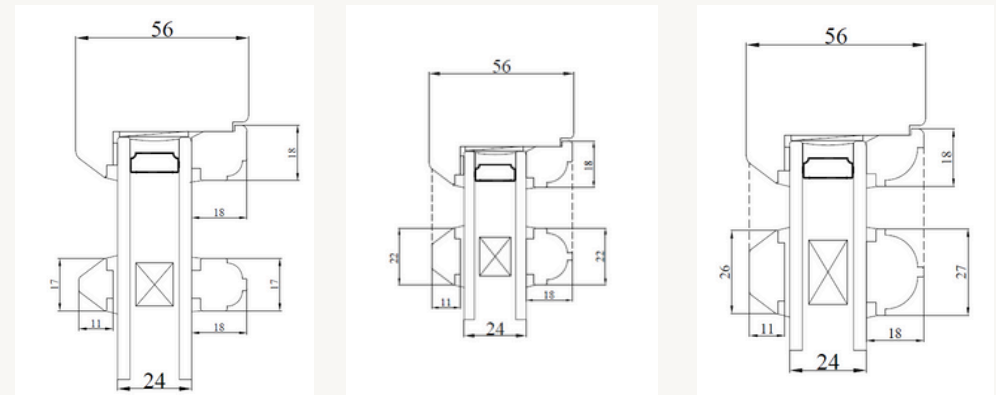

LAMB - SIZES 17/20/22/26 MM

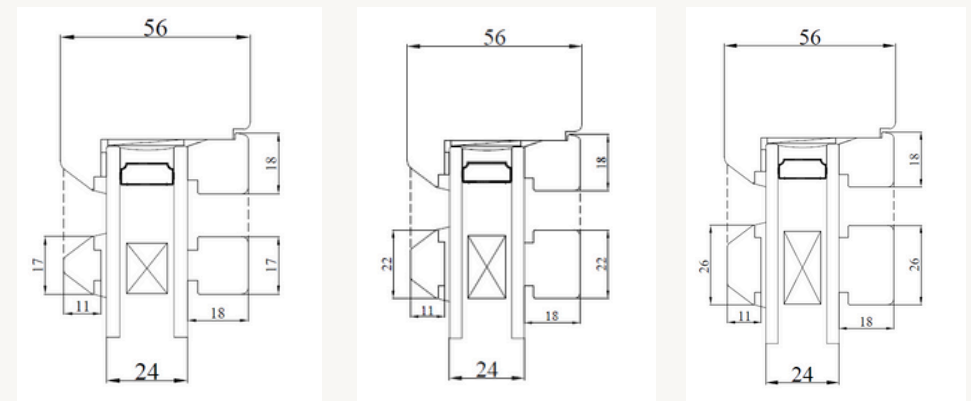

TYPES OF BARS

SOLID BARS

FOR INTERNALLY GLAZED WINDOWS
(STANDARD GLASS UNIT 24MM) - 48MM

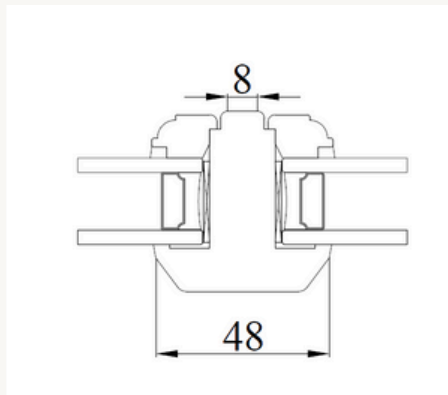

FOR INTERNALLY GLAZED DOORS
(STANDARD GLASS 24MM) -
48/60/78/100/106/136/156/200 MM

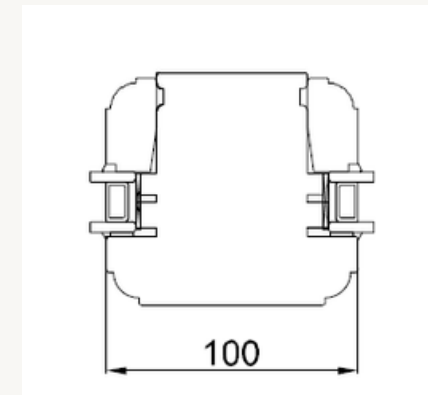

SOLID BARS FOR PUTTY IMITATION WITH SINGLE/ SLIMLINE GLASS
(EXTERNALLY GLAZED)

SIZES - 22/24 MM

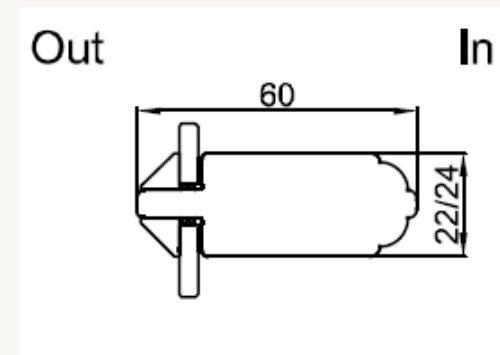
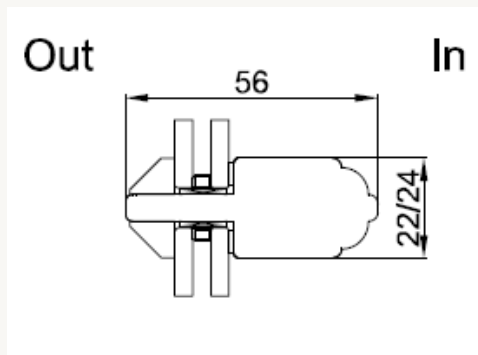

TYPES OF BARS

LEADED BARS

AVAILABLE IN MANY CONFIGURATIONS,
WITH COLOURFUL FOILS, IN MANY
PATTERNS

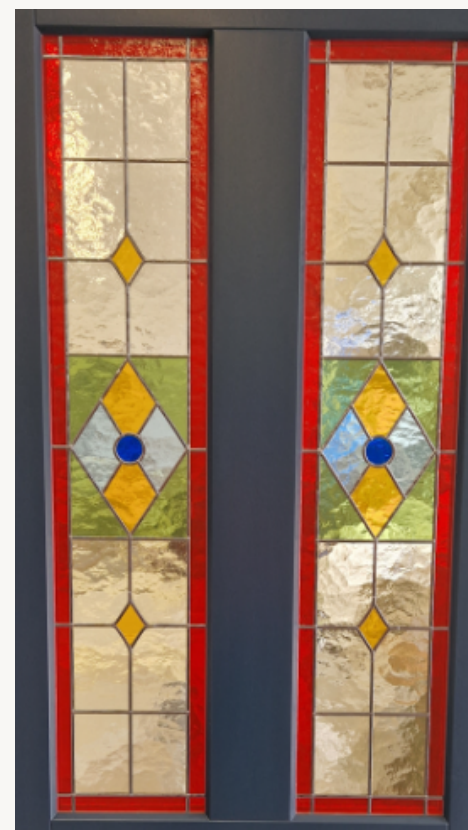

SPACER BARS

SILVER ALUMINIUM

CALLED "COLD SPACER BAR"
NO EXTRA CHARGE

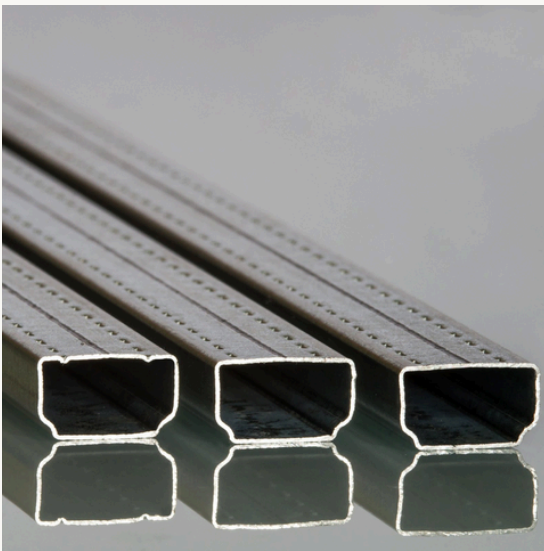

WARM SWISSPACER

MADE FROM INSULATING COMPOSITE
MATERIAL

TWO TYPES AVAILABLE:

- ADVANCE
- ULTIMATE

AVAILABLE COLOURS:

- LIGHT GREY RAL 7035
- GREY RAL 9023
- LIGHT BROWN RAL 8003
- DARK BROWN RAL 8014
- BLACK RAL 9005
- WHITE RAL 9016



TYPES OF GLASS

STANDARD (ANNEALED)



THE MOST POPULAR GLASS. BREAKS EASILY, TYPICALLY INTO LARGE, SHARP PIECES

SAFETY - TOUGHENED



RESISTANT TO BREAKAGE, FOUR TIMES STRONGER COMPARED TO ANNEALED GLASS. WHEN BROKEN, IT CRUMBLES INTO SMALL, BLUNT FRAGMENTS, REDUCING THE RISK OF INJURY

SAFETY - LAMINATED



MADE BY BONDING TWO OR MORE LAYERS OF GLASS. WHEN BROKEN, SHARDS STAY ATTACHED, OFFERING SAFETY, SECURITY AND SOUND INSULATION

TYPES OF GLASS

ACOUSTIC



REDUCES SOUND TRANSMISSION, PROVIDING ENHANCED NOISE INSULATION - IDEAL FOR URBAN ENVIRONMENTS OR NEAR BUSY ROADS

SOLAR CONTROL



MINIMIZES HEAT GAIN FROM SUNLIGHT WHILE ALLOWING NATURAL LIGHT, IMPROVING ENERGY EFFICIENCY AND COMFORT

FIRE RATED



MAINTAINS INTEGRITY UNDER HIGH TEMPERATURES, PROVIDING PROTECTION BY CONTAINING FIRE AND SMOKE FOR A SPECIFIED PERIOD (EW/EI)

ALL AVAILABLE IN MANY VARIANTS AND CONFIGURATIONS

TYPES OF GLASS

OBSCURE - FROSTED



OFFERS A SMOOTH, TRANSLUCENT FINISH THAT DIFFUSES LIGHT WHILE MAINTAINING PRIVACY, IDEAL FOR BATHROOMS OR PARTITIONS

OBSCURE - SANDBLASTED

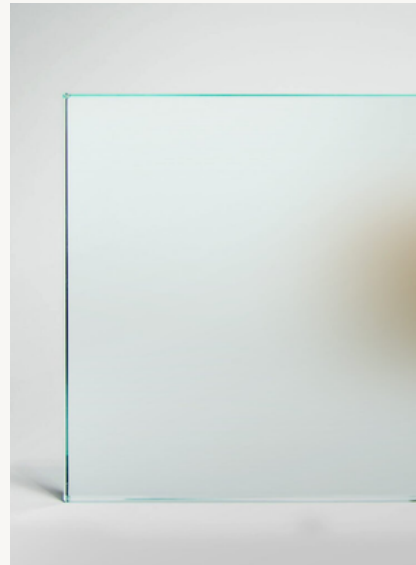

ACHIEVES A SIMILAR EFFECT BUT CAN INCLUDE CUSTOM PATTERNS OR DESIGNS, CREATED BY BLASTING THE SURFACE WITH FINE SAND FOR A UNIFORM MATTE TEXTURE

OBSCURE - ORNAMENTAL

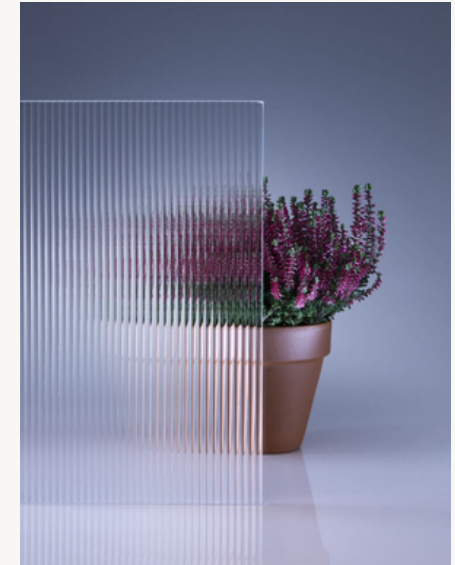

FEATURES DECORATIVE EMBOSSED DESIGNS THAT COMBINE PRIVACY WITH AESTHETIC APPEAL, COMMONLY USED IN DOORS AND WINDOWS TO ADD CHARACTER

ALL AVAILABLE IN MANY VARIANTS AND CONFIGURATIONS.

ORNAMENTAL GLASS

MASTER - POINT

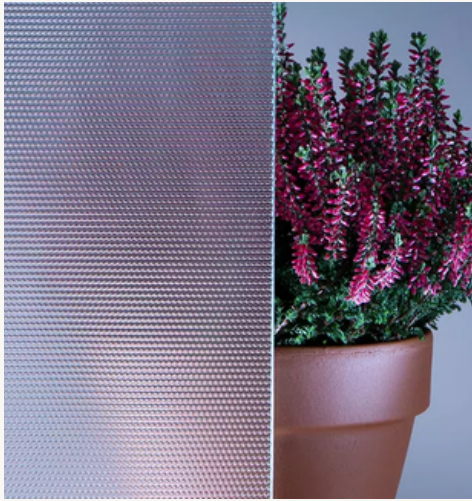

MASTER CAREE

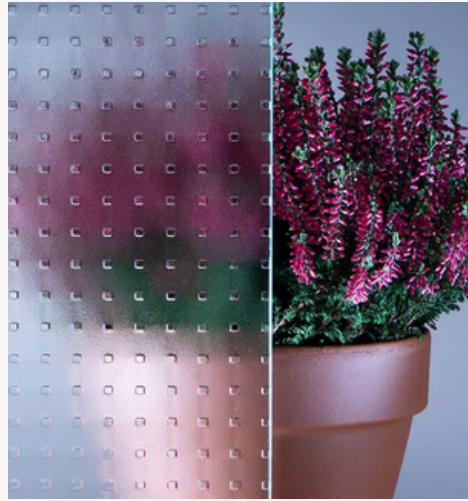

VISION (CHINCHILA)

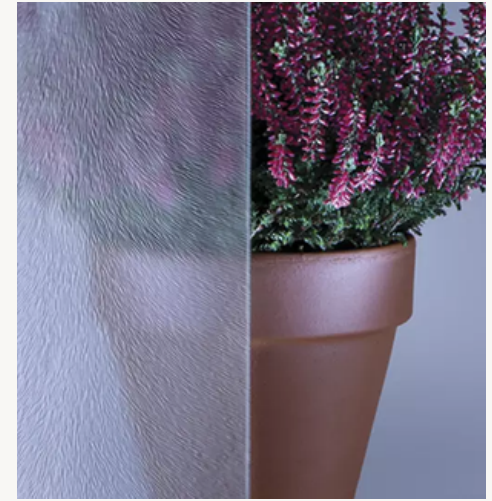

MONUMENTAL M/S



SILVIT (KURA)



LALIVA (DELTA)



ORNAMENTAL GLASS

KATEDRAL



FLUTES

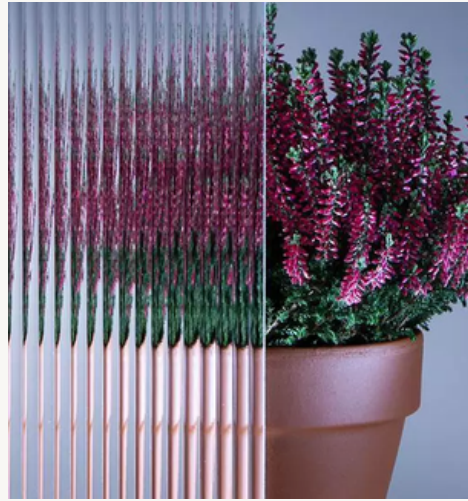

ARENA C (CREPI)

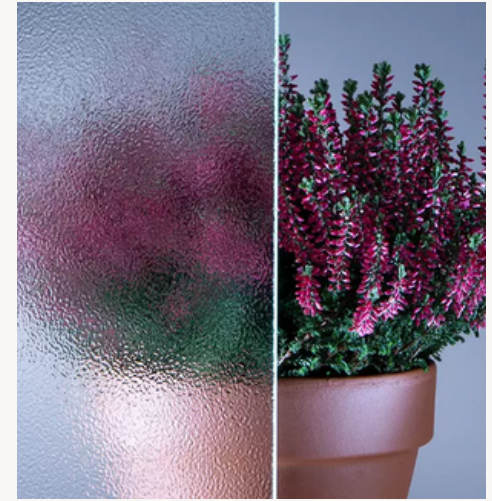

MONUMENTAL M/S



SILVIT (KURA)



LALIVA (DELTA)



TYPES OF GLASS

VACUUM INSULATED GLASS “ENHANCE” FROM LANDVAC



- AN INNOVATIVE INSULATING GLASS THAT USES A VACUUM CAVITY BETWEEN TWO PANES TO ACHIEVE EXCEPTIONAL THERMAL PERFORMANCE WHILE MAINTAINING A SLIM PROFILE
- EXCELLENT ENERGY EFFICIENCY ($U= 0.4 \text{ W/M}^2\text{K}$)
- THICKNESS 8.3MM ($4\text{TL}+0.3\text{V}+4\text{T}$)
- HIGH ACOUSTIC INSULATION 39DB
- SAFETY (TEMPERED PANES)
- SUPERIOR COMFORT COMPARED TO TRADITIONAL GLASS
- IDEAL FOR BOTH MODERN AND HERITAGE PROJECTS WHERE SLIM SECTIONS ARE REQUIRED

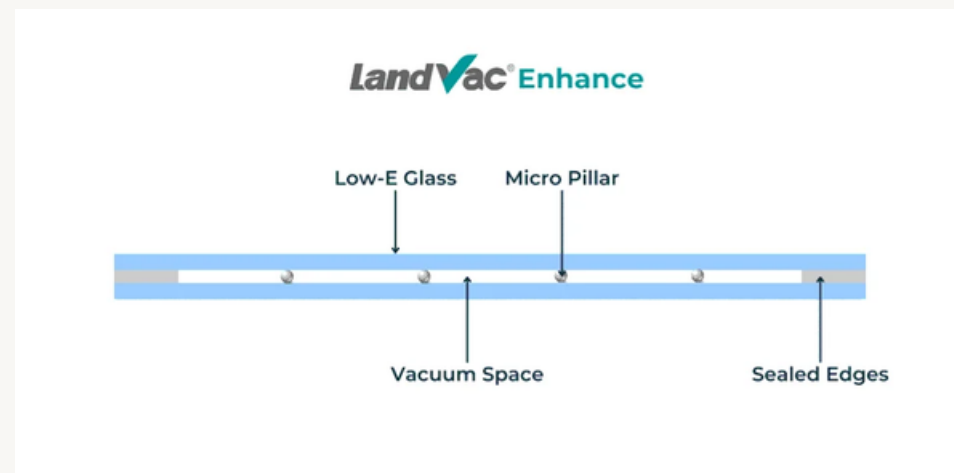

DOORS

HARDWARE

HINGES

NICO 3D



FINISHES:

- POLISHED CHROME
- SATIN CHROME
- POLISHED BRASS
- BLACK
- WHITE

CONCEALED HINGES - ATOMICA

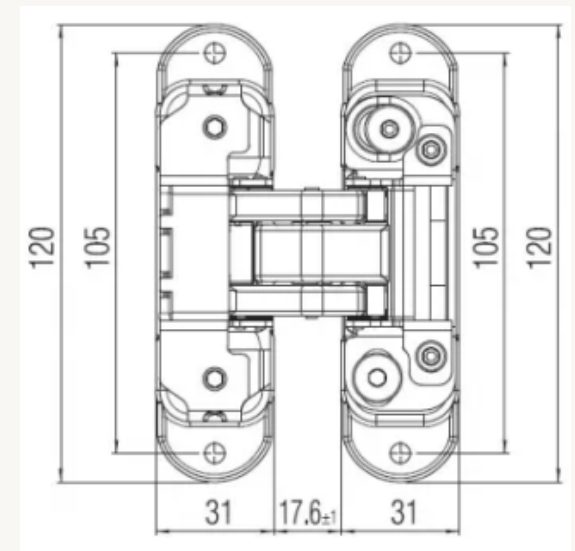
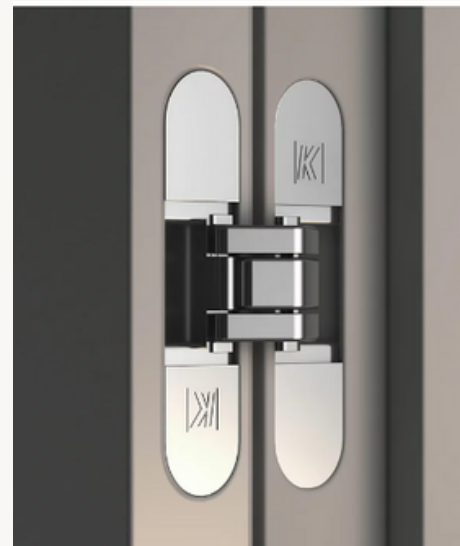

FINISHES:

- POLISHED CHROME
- SATIN CHROME
- POLISHED BRASS
- ANTIQUE BRASS
- BRONZE
- NICKEL MATT
- BLACK
- WHITE

HARDWARE

HANDLES

MILA PROLINEA LEVER HANDLE 240 MM



Polished Gold



Polished Chrome



Smokey Chrome



Smooth Satin
Chrome



White



Black

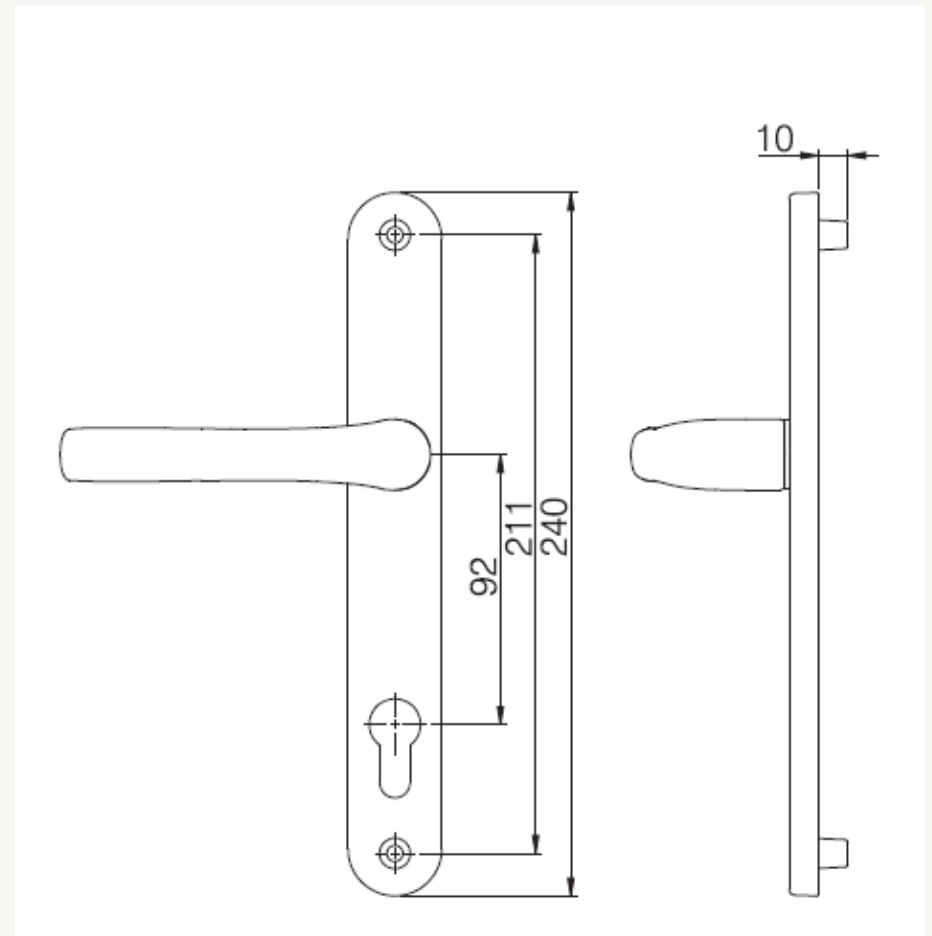

HARDWARE

OTHER DOOR HANDLES

MILA PROSTYLE OVAL
LEVER HANDLE 240MM

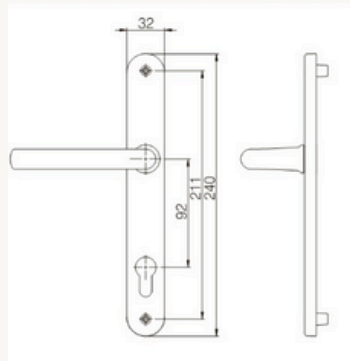

FINISHES:

- POLISHED CHROME
- SMOOTH SATIN CHROME
- POLISHED GOLD
- SMOKEY CHROME
- BLACK
- WHITE

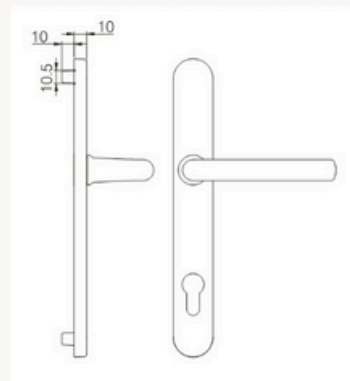

MILA PROSTYLE SWEEP
LEVER HANDLE 240 MM

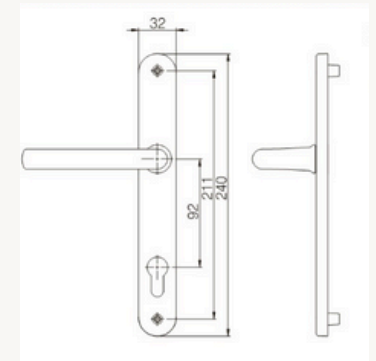

FINISHES:

- POLISHED CHROME
- SMOOTH SATIN CHROME
- POLISHED GOLD
- SMOKEY CHROME
- BLACK
- WHITE

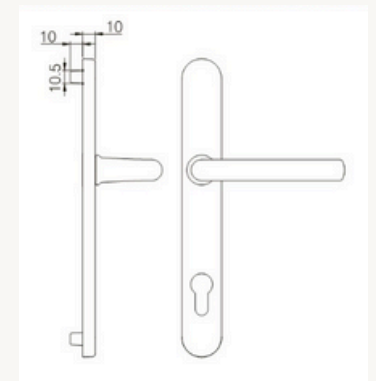

HARDWARE

OTHER DOOR HANDLES

MILA PROSTYLE ROUND LEVER HANDLE 240MM



- FINISHES:
- POLISHED CHROME
 - SMOOTH SATIN CHROME
 - POLISHED GOLD
 - SMOKEY CHROME
 - BLACK
 - WHITE

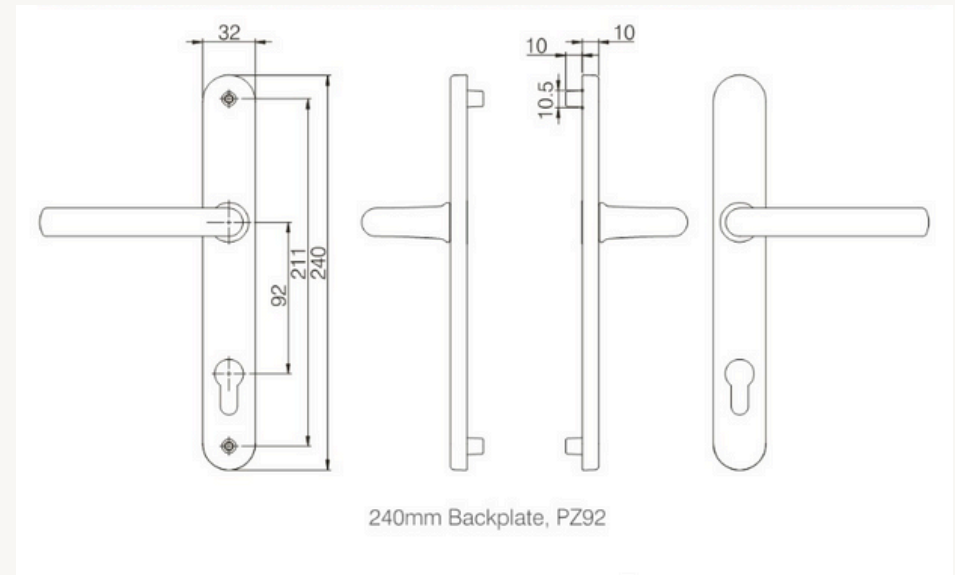

HARDWARE

OTHER DOOR HANDLES

COASTAL MITRE LEVER DOOR HANDLE KM078C (249MM)

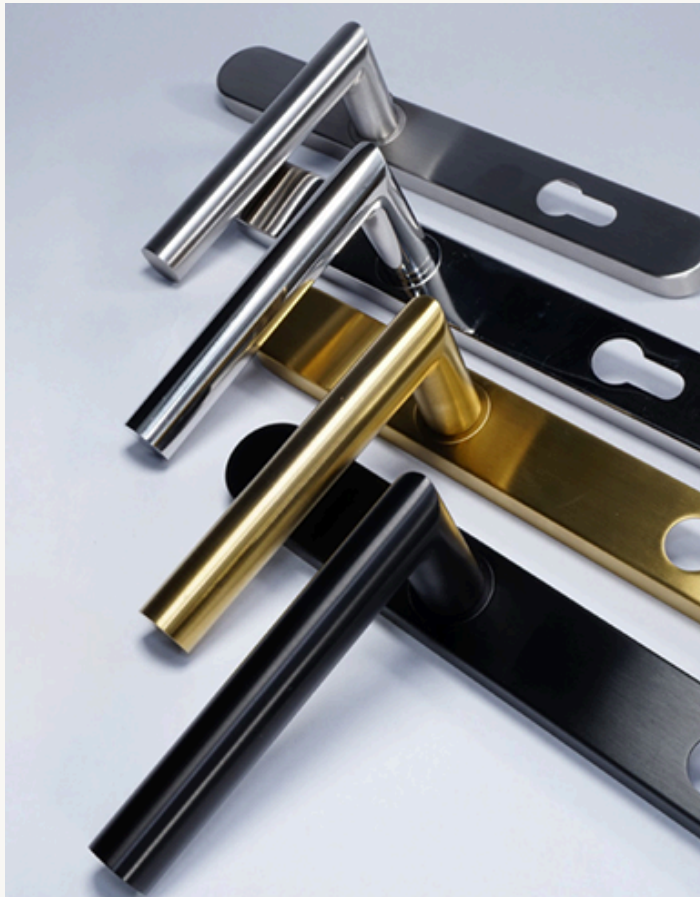

Finishes Available



KM078-SSS
Satin Stainless Steel



KM078-PSS
Polished Stainless Steel



KM078-PSB
PVD Stainless Satin Brass



KM078-MBL
Matt Black Lacquer

HARDWARE

OTHER DOOR HANDLES

MILA HERITAGE 240MM

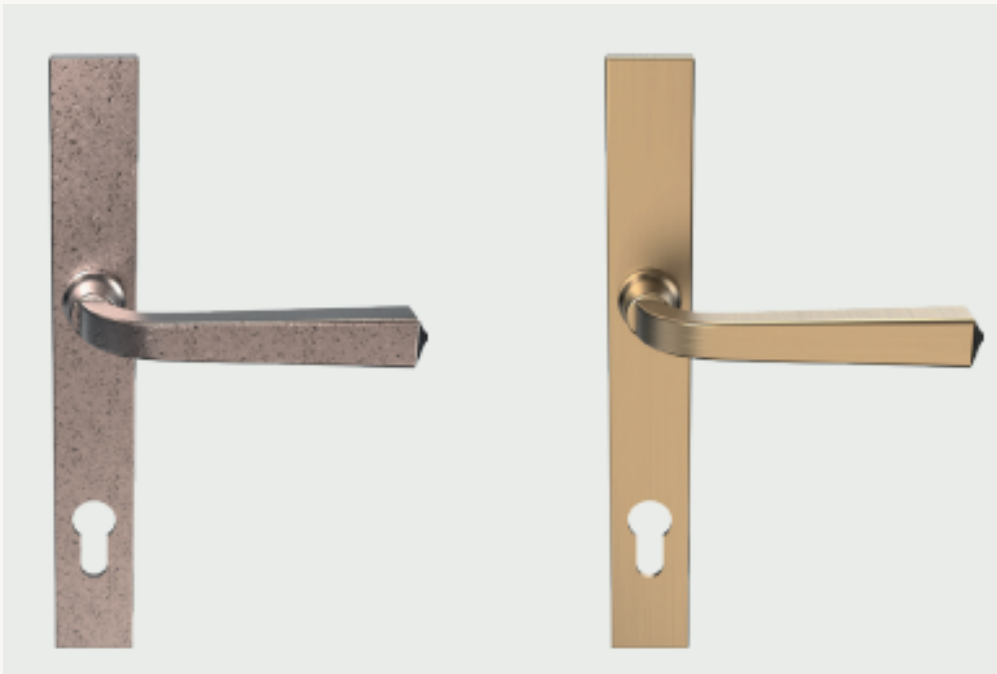

FINISHES:

- POLISHED CHROME
- SATIN CHROME
- POLISHED BRASS
- WHITE
- MATT BLACK
- HERITAGE BLACK
- PEWTER PATINA
- ANTIQUÉ BRONZE
- HERITAGE PEWTER

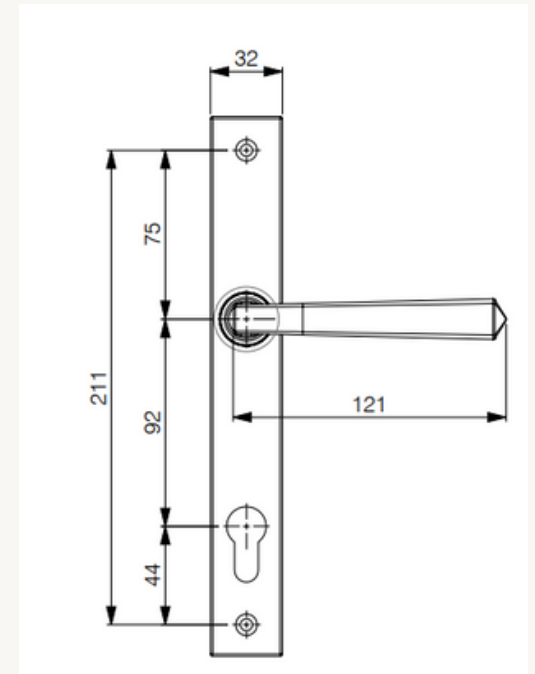

HARDWARE

PULL ESCUTCHEONS

MILA SUPA SECURE PULL ESCUTCHEON

ENHANCED SECURITY LEVEL,
SBD CERTIFICATE AND "TWO
STARS"



FINISHES:

- POLISHED CHROME
- SATIN CHROME
- POLISHED BRASS

MILA SUPA PULL ESCUTCHEON

BASIC SECURITY LEVEL,
WITHOUT CERTIFICATES



FINISHES:

- POLISHED CHROME
- SATIN CHROME
- POLISHED BRASS

MILA PRO LINEA DOOR PULL

BASIC SECURITY LEVEL,
WITHOUT CERTIFICATES



FINISHES:

- BLACK
- WHITE

HARDWARE

PULL ESCUTCHEONS

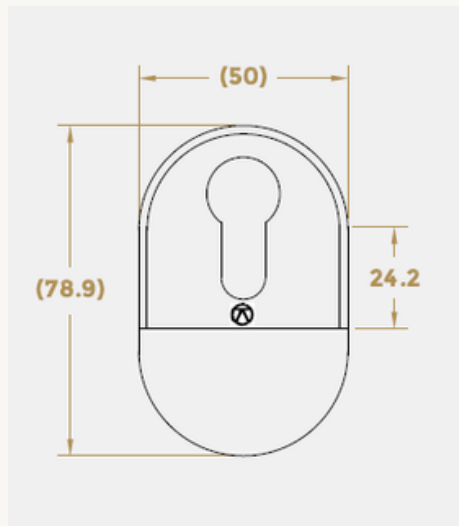

COASTAL CP76 PULL ESCUTCHEON

MARINE GRADE STAINLESS
STEEL

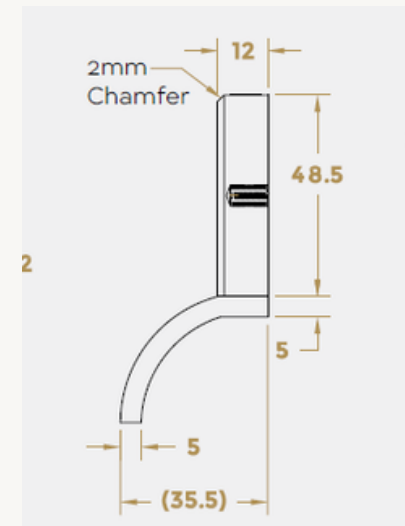

SSS
Satin Stainless Steel



PSS
Polished Stainless Steel

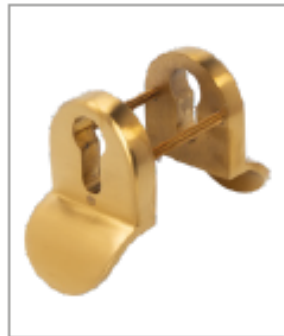

PSB
PVD Satin Brass



PPB
PVD Polished Brass



MBL
Matt Black Lacquer

HARDWARE

ESPAGNOLETTE - MULTIPOINT LOCKING SYSTEM

AUTOMATIC WINKHAUS AV4

WITH A MAGNET (MAGNET IMPROVES THE HOOK TRIGGERING SYSTEM) WHICH AUTOMATICALLY RELEASES HOOKS DURING THE DOOR'S CLOSING (PUSHING THE DOOR) :

- FOR SINGLE DOOR
- FOR DOUBLE DOORS (FRENCH DOORS) ONLY FOR MASTER SASH WITH HANDLE + SLAVE SASH WITH SHOOT BOLTS

AUTOMATIC WINKHAUS AV2 HERITAGE

WITH UPPER ESCUTCHEON (DOUBLE PULL), OPENING AND CLOSING BY KEY IN CYLINDER LOCK. MOSTLY WITH THUMB TURN CYLINDER LOCK:

- FOR SINGLE DOOR
- FOR DOUBLE DOORS (FRENCH DOORS) ONLY FOR MASTER SASH WITH UPPER ESCUTCHEON + SLAVE SASH WITH SHOOT BOLTS

LEVER OPERATED FGTE

FOR DOUBLE DOORS (FRENCH DOORS WITH DOUBLE HANDLE) – BOTH SASHES WITH TWO INDEPENDENT MULTIPOINT LOCKS, BOTH SASHES OPENING AND CLOSING SEPARATELY/ INDEPENDENTLY (MASTER SASH FIRST)

HARDWARE

LETTER BOX

MILA PRO STYLE



FINISHES:

- POLISHED CHROME
- SATIN CHROME
- SMOKEY CHROME
- POLISHED BRASS
- BLACK
- WHITE

COASTAL LP400 SLEEVED



MARINE GRADE STAINLESS STEEL

HARDWARE

CYLINDER LOCKS

ISEO F5

STANDARD CYLINDER LOCK WITH 3 KEYS, BASIC PROTECTION, FOR ALL DOORS WITHOUT ADDITIONAL CHARGE



ISEO R6 EXTRA

CYLINDER LOCK WITH INCREASED LEVEL OF SECURITY, COMES WITH 5 KEYS AND CARD WITH CODE WHICH HELPS TO BUY EXTRA KEYS

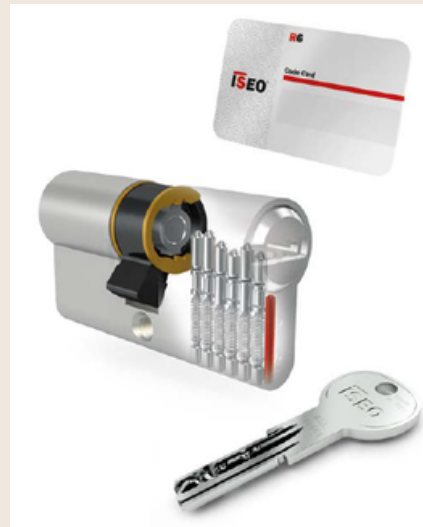

ISEO R7 EXTRA

CYLINDER LOCK WITH INCREASED LEVEL OF SECURITY, COMES WITH 5 KEYS AND CARD WITH A CODE WHICH HELPS TO BUY EXTRA KEYS. ESPECIALLY USED IN BI-FOLD DOORS

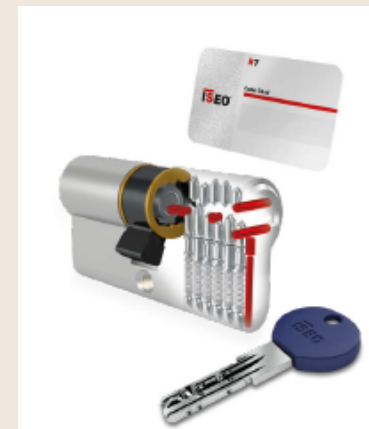

HARDWARE

TRICKLE VENTS

TITON XS13/S13

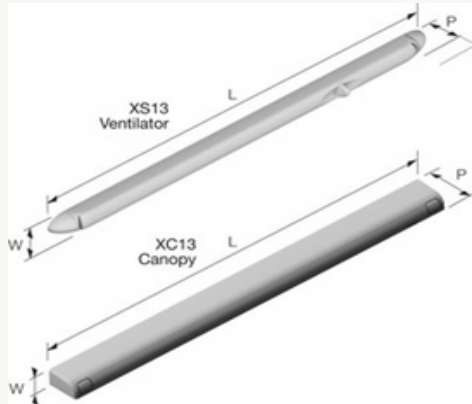

- FINISHES:
- TOFFIE
 - BROWN
 - BLACK
 - BRIGHT WHITE

TRYKVENT 389/283



- FINISHES:
- WHITE
 - BROWN
 - GRAY

HARDWARE

TRICKLE VENTS

TITON XS13/S13 AND TRYKVENT 389/283

AVAILABLE OPTIONS :

INSTALLED IN FRAME

- WITH FLAT GRILLE AND WOODEN HEAD DRIP
- WITH CANOPY FROM OUTSIDE
- HIDDEN (NO VISIBLE VENT FROM OUTSIDE) - AVAILABLE ONLY IN FLUSH DOOR INLINE 79MM

INSTALLED IN DOOR SASH:

- WITH CANOPY FROM OUTSIDE

FLUSH DOOR INLINE

MAIN DOOR SYSTEM

AVAILABLE IN MANY
CONFIGURATIONS

EACH TIME IT'S
CUSTOMIZED TO
INDIVIDUAL ORDERS
AND PROJECTS

AVAILABLE IN OPTIONS
FOR OPENING INWARDS
AND OUTWARDS



TECHNICAL DRAWINGS

FLUSH DOOR IN

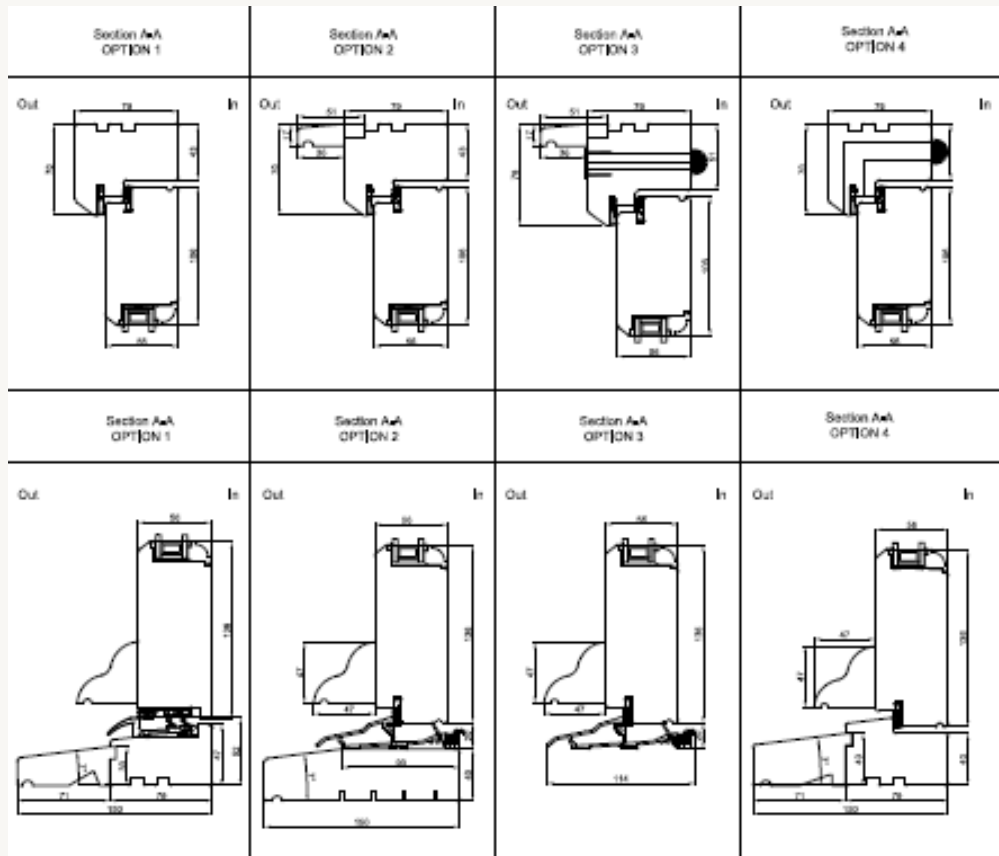
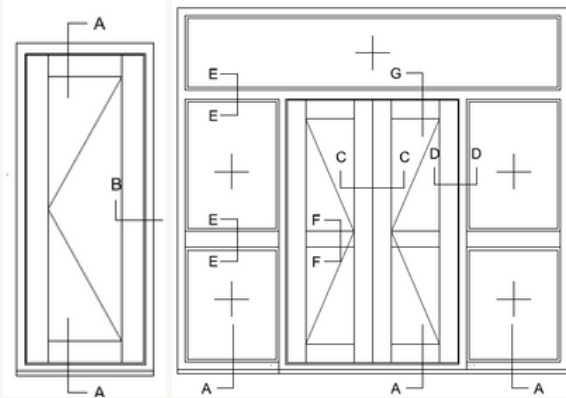

FLUSH DOOR OUT

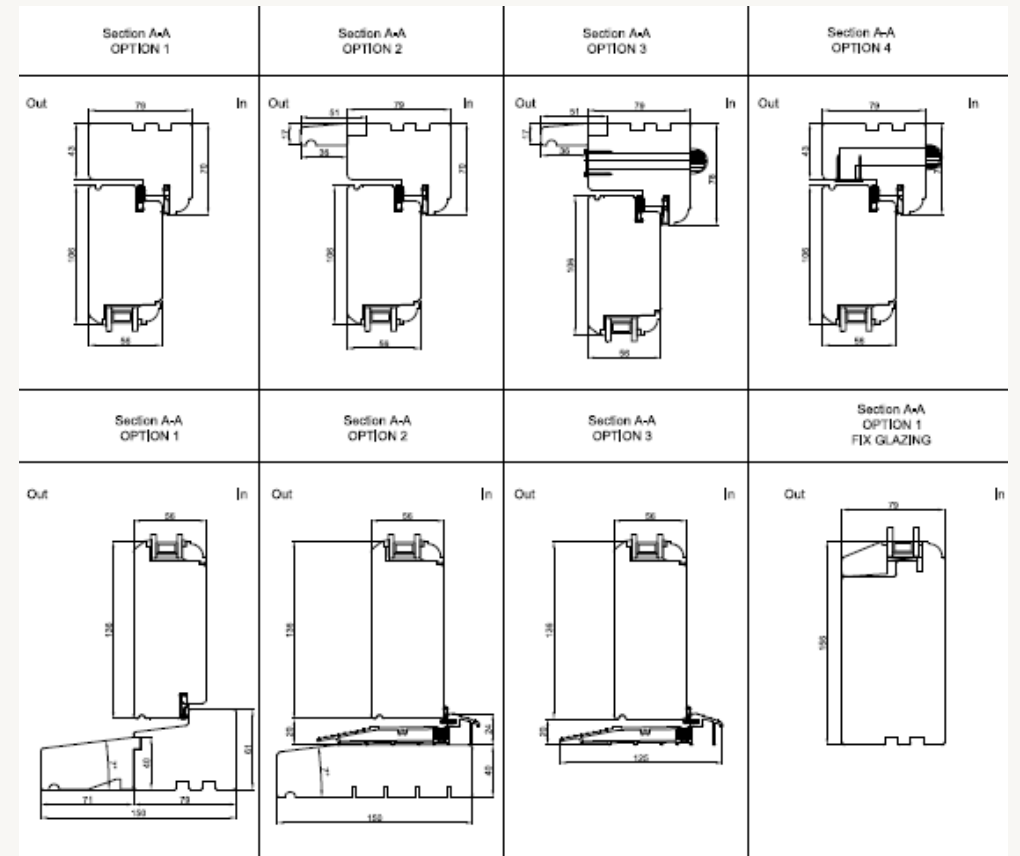
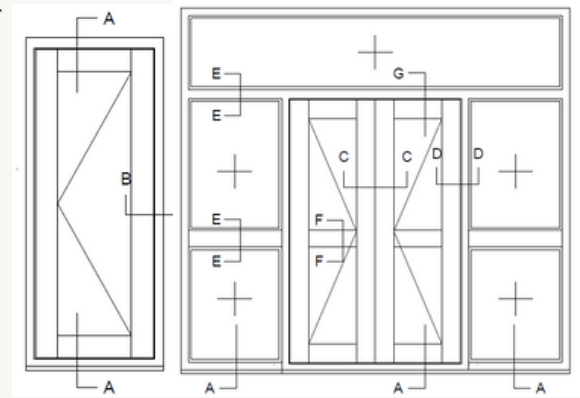

TECHNICAL DRAWINGS

FLUSH DOOR IN - ATOMICA HINGES

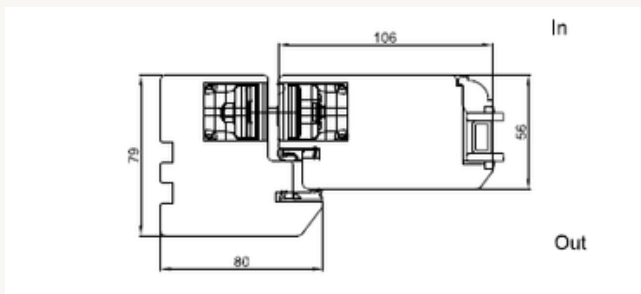
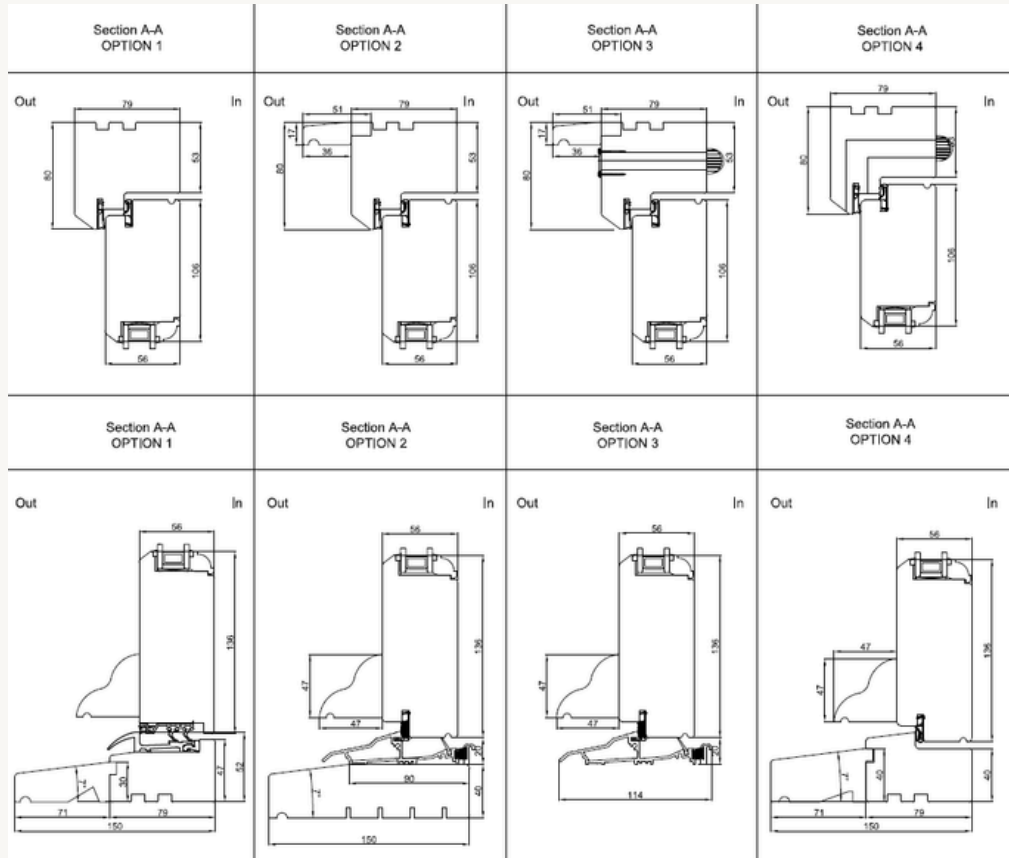

FLUSH DOOR OUT - ATOMICA HINGES

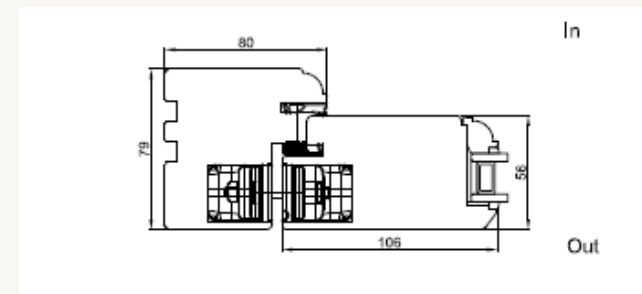
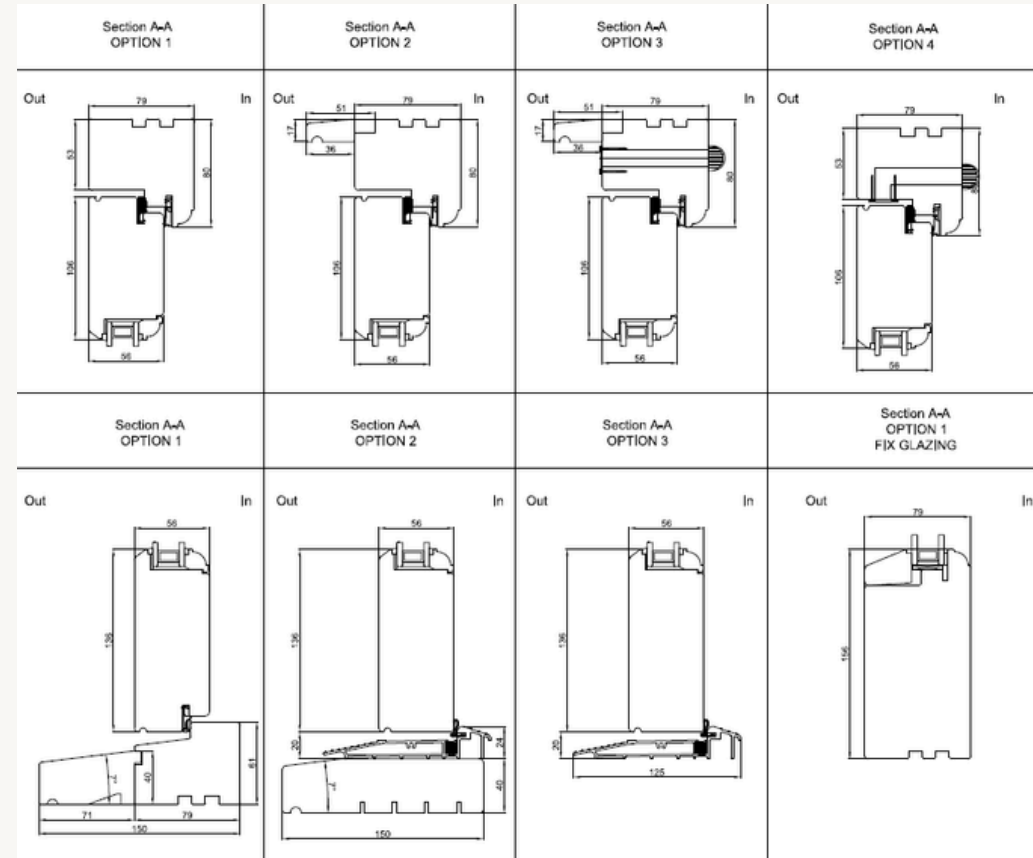

FLUSH DOOR SD

SECOND DOOR SYSTEM -
THICKER FRAME AND
DOOR SASH THAN FLUSH
DOOR INLINE

SYSTEM ALLOWS FOR
THICKER GLASS UNITS
AND OFFERS GREAT
FLEXIBILITY IN CREATING
VARIOUS STYLES



TECHNICAL DRAWINGS

FLUSH DOOR SD IN - FRAME OVOLO/ SQUARE

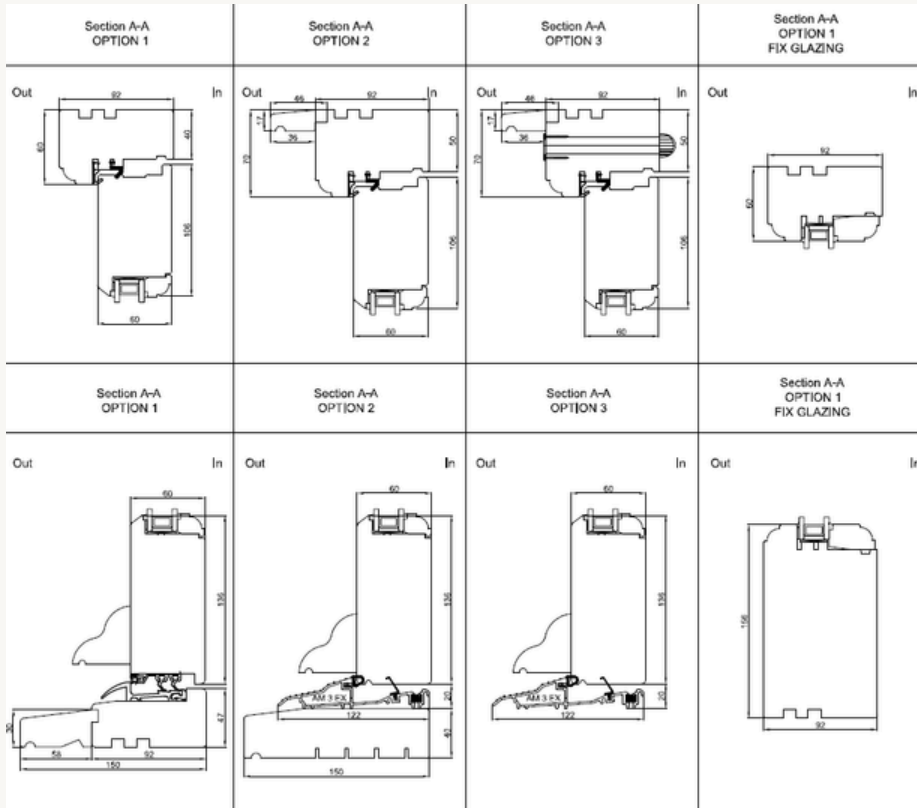
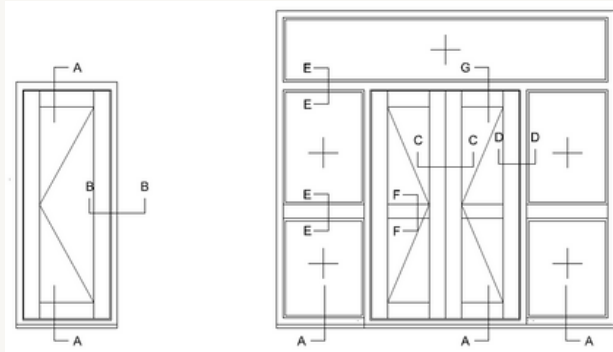

FLUSH DOOR SD OUT - FRAME OVOLO/ SQUARE

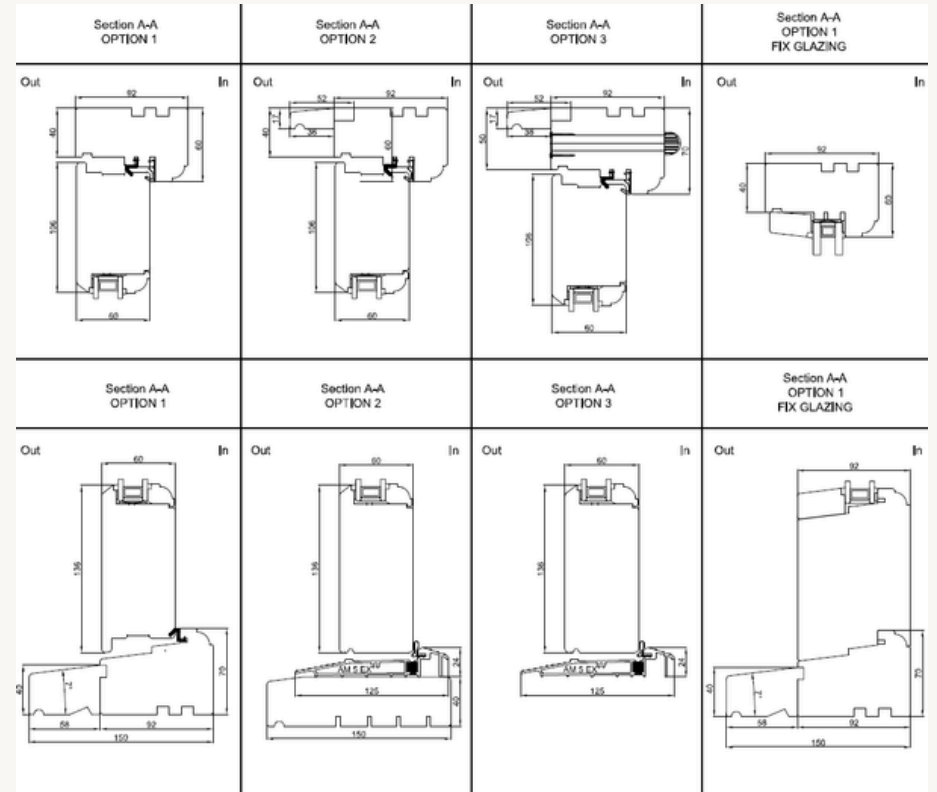
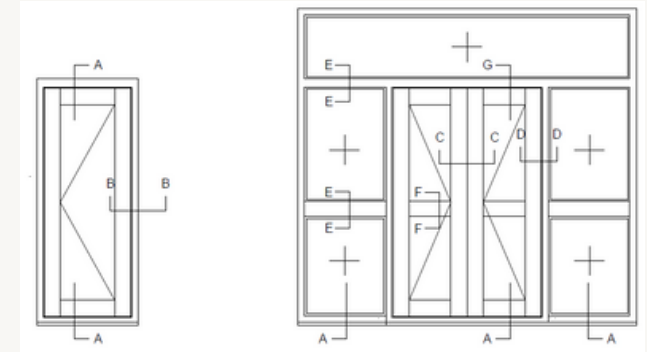

TECHNICAL DRAWINGS

FLUSH DOOR IN SD - ATOMICA HINGES

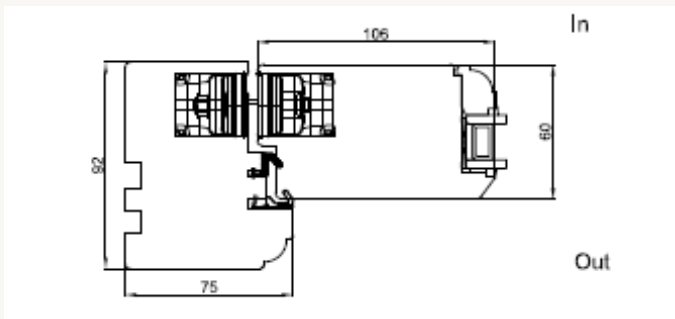
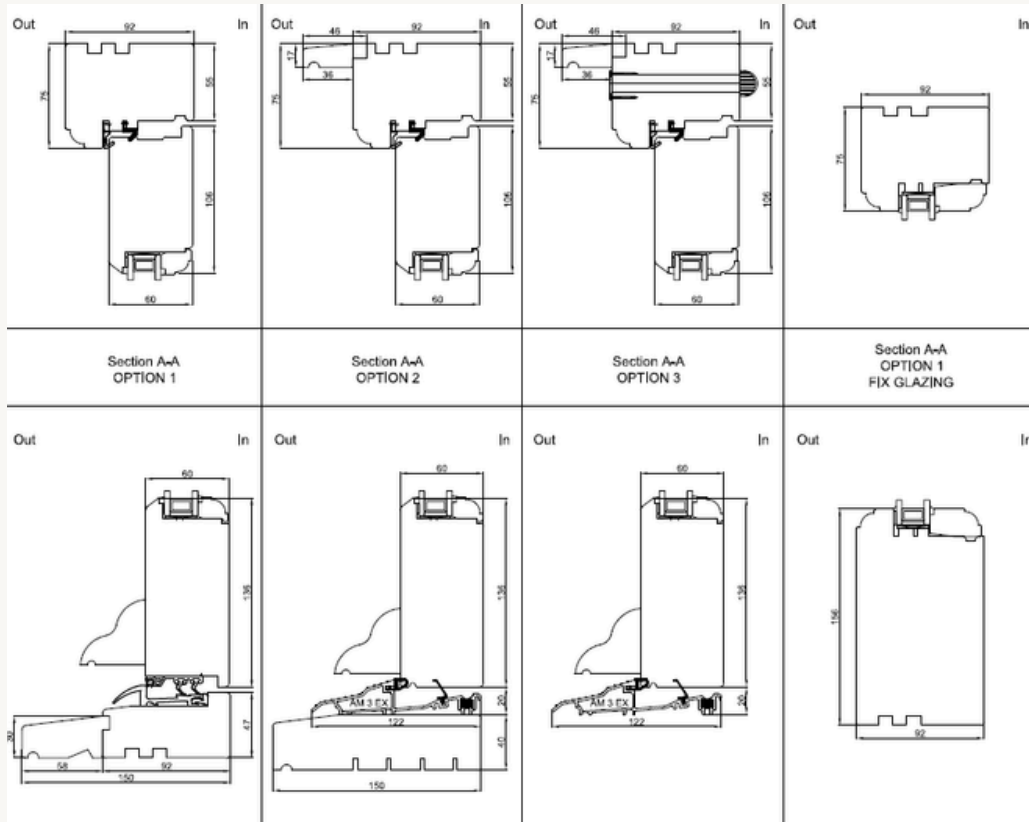

FLUSH DOOR OUT SD - ATOMICA HINGES

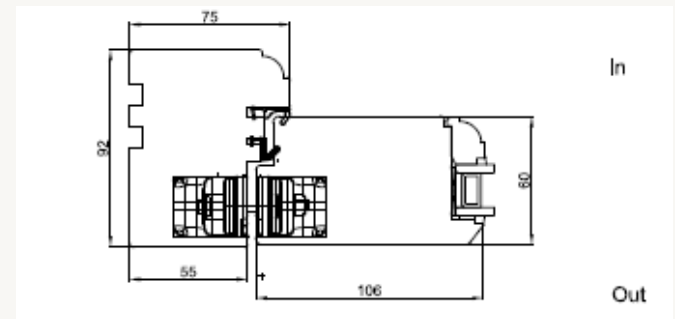
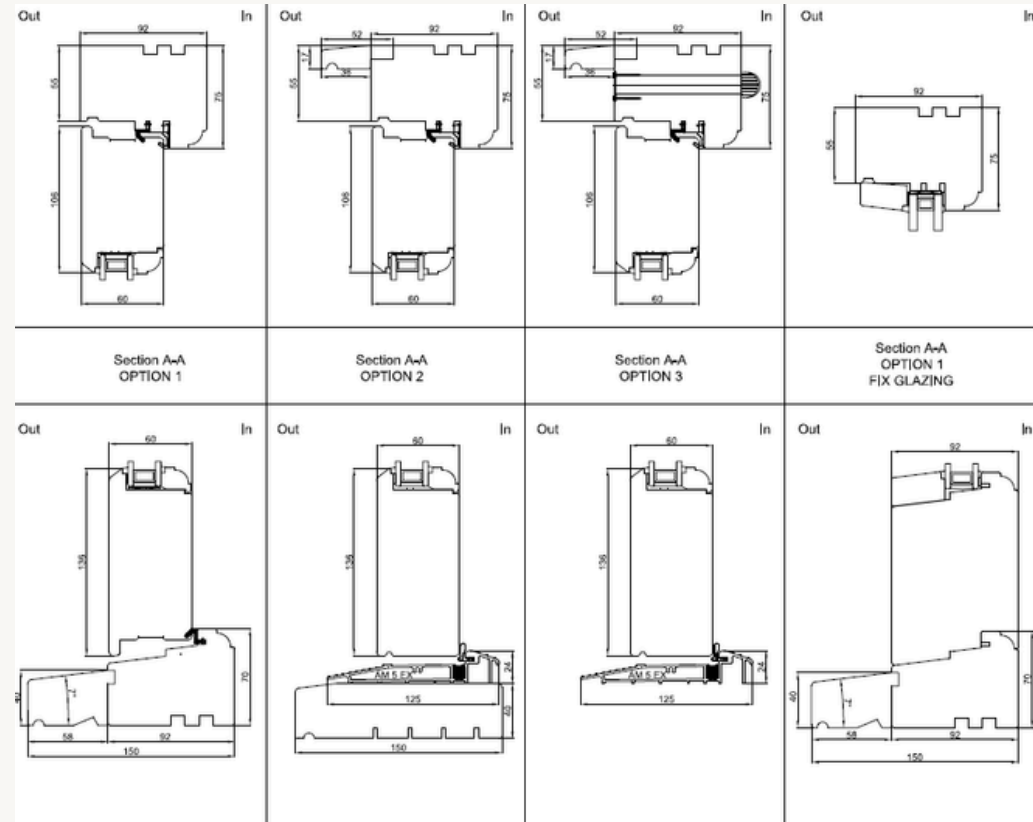

FRONT DOOR SCHEMES



AMWELL ONE



AMWELL TWO

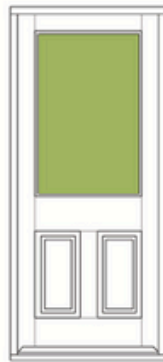

AMWELL TREE



HAMPSTED



PARLIAMENT



ARCHWAY



CHELSEA



HADLEY ONE

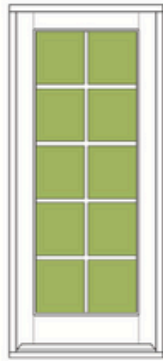

HADLEY TWO

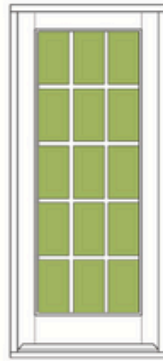

HADLEY THREE

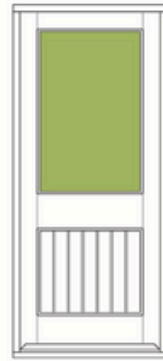

MUSWELL



HIGHGATE

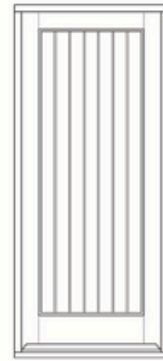

TRENT

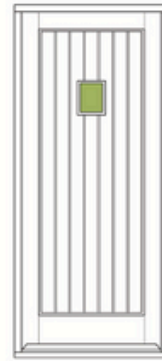

TRENT TWO



WILSTEAD

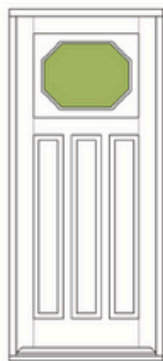

HARBURY

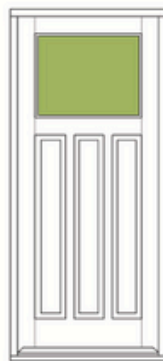

BIRCH

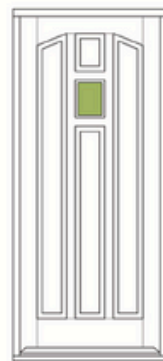

BEAMFORD

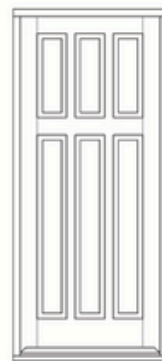

ASTONBURY

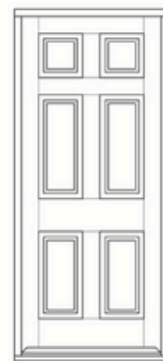

KENSINGTON

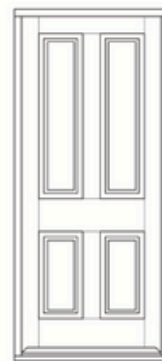

OXFORD

BI-FOLD DOORS

TRADITIONAL OPTION FOR
LARGE, OPENABLE
CONSTRUCTIONS WITH
EXTENSIVE GLAZING

BI-FOLD DOORS GIVE
PLENTY OF SPACE AND
SUNLIGHT

CENTOR FITTINGS FINISHES:

- PVD APPLIED BRONZE
(ALMOST BLACK)
- PVD APPLIED BRASS
- POLISHED STAINLESS STEEL
- POLISHED STAINLESS STEEL



OPENING OPTIONS

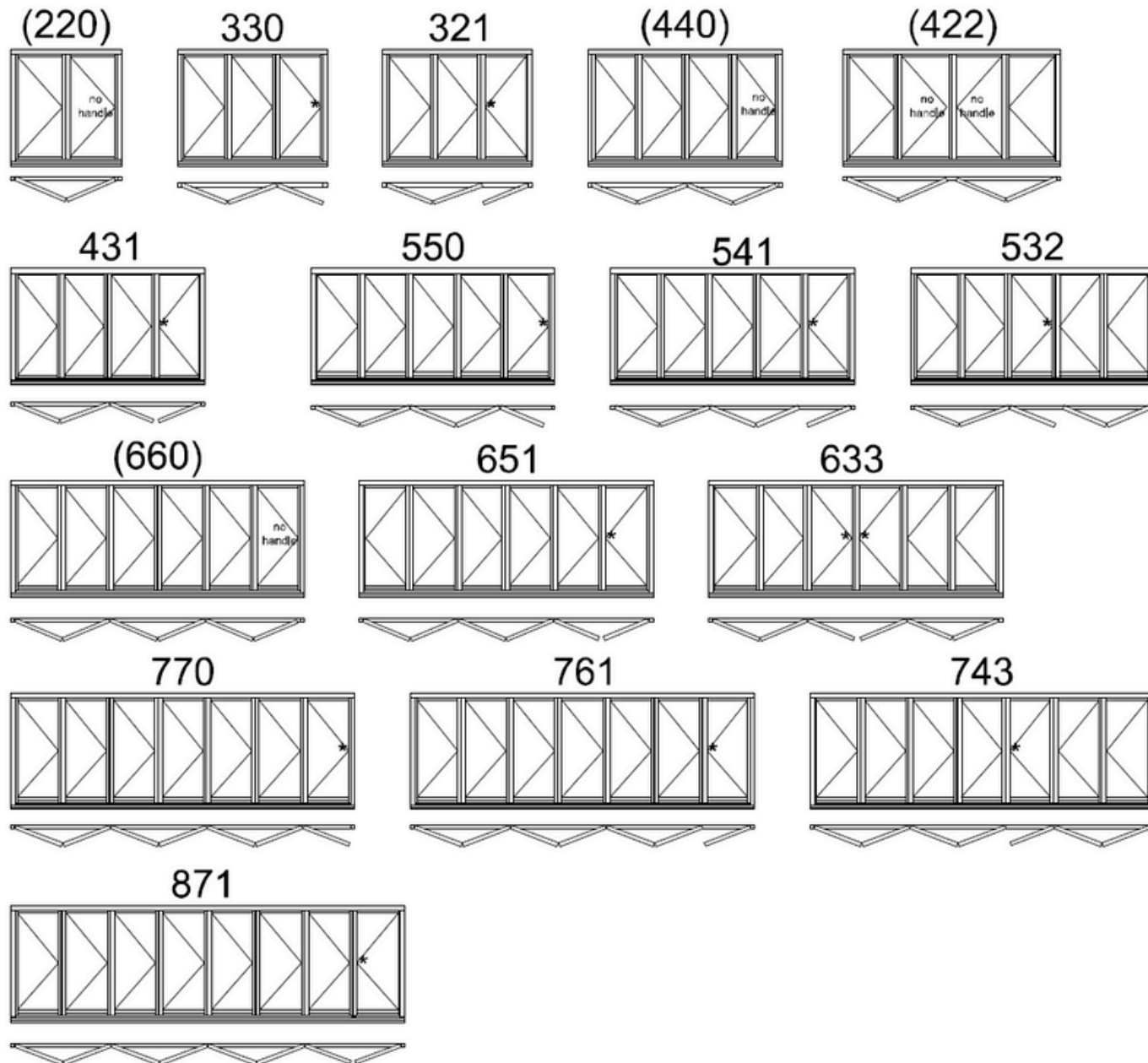

HARDWARE

CENTOR SYSTEM E3 OR F3

HANDLES - THE SAME AS
IN FLUSH DOORS

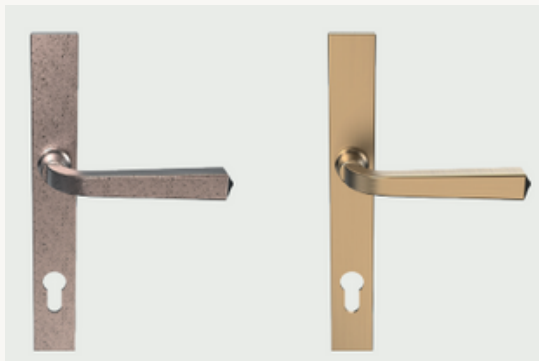

FINISHES LIKE DESCRIBED IN
CATALOGUE

SHOOT BOLTS

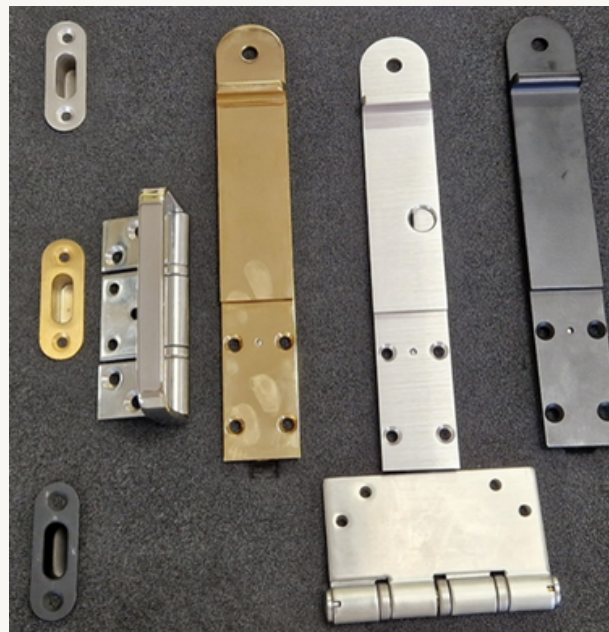

MAGNETS AND DOOR
CATCHES FOR ACCESS
PANELS



ONLY BLACK



FINISHES THE
SAME AS
SHOOT BOLTS

HARDWARE

TRICKLE VENTS

TITON XS13/S13



- FINISHES:
- TOFFIE
 - BROWN
 - BLACK
 - BRIGHT WHITE

TRYKVENT 389/283



- FINISHES:
- WHITE
 - BROWN
 - GRAY

HARDWARE

TRICKLE VENTS

TITON XS13/S13 AND TRYKVENT 389/283

AVAILABLE OPTIONS :

INSTALLED IN FRAME

- WITH CANOPY FROM OUTSIDE

INSTALLED IN DOOR SASH:

- WITH CANOPY FROM OUTSIDE

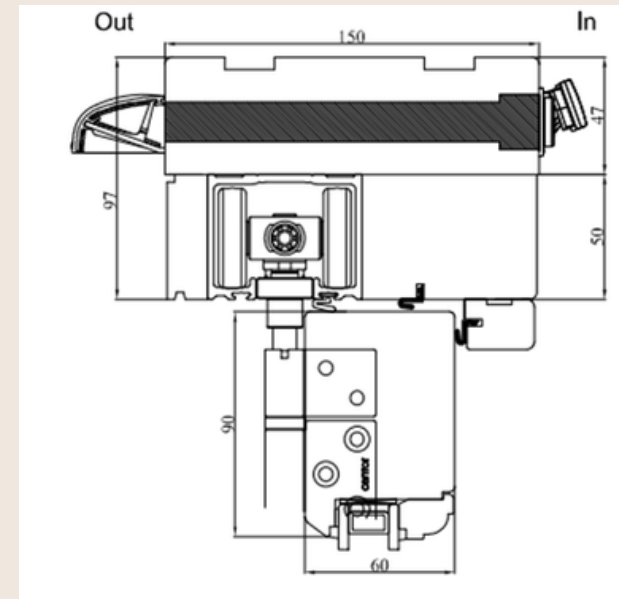

TECHNICAL DRAWINGS

BI -FOLD CENTOR E3

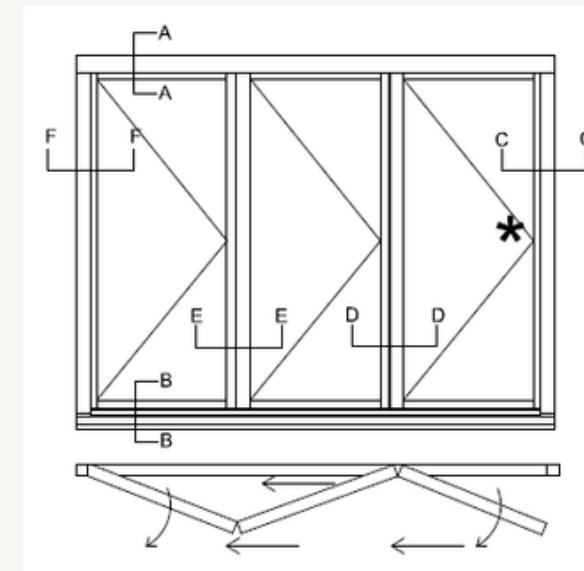
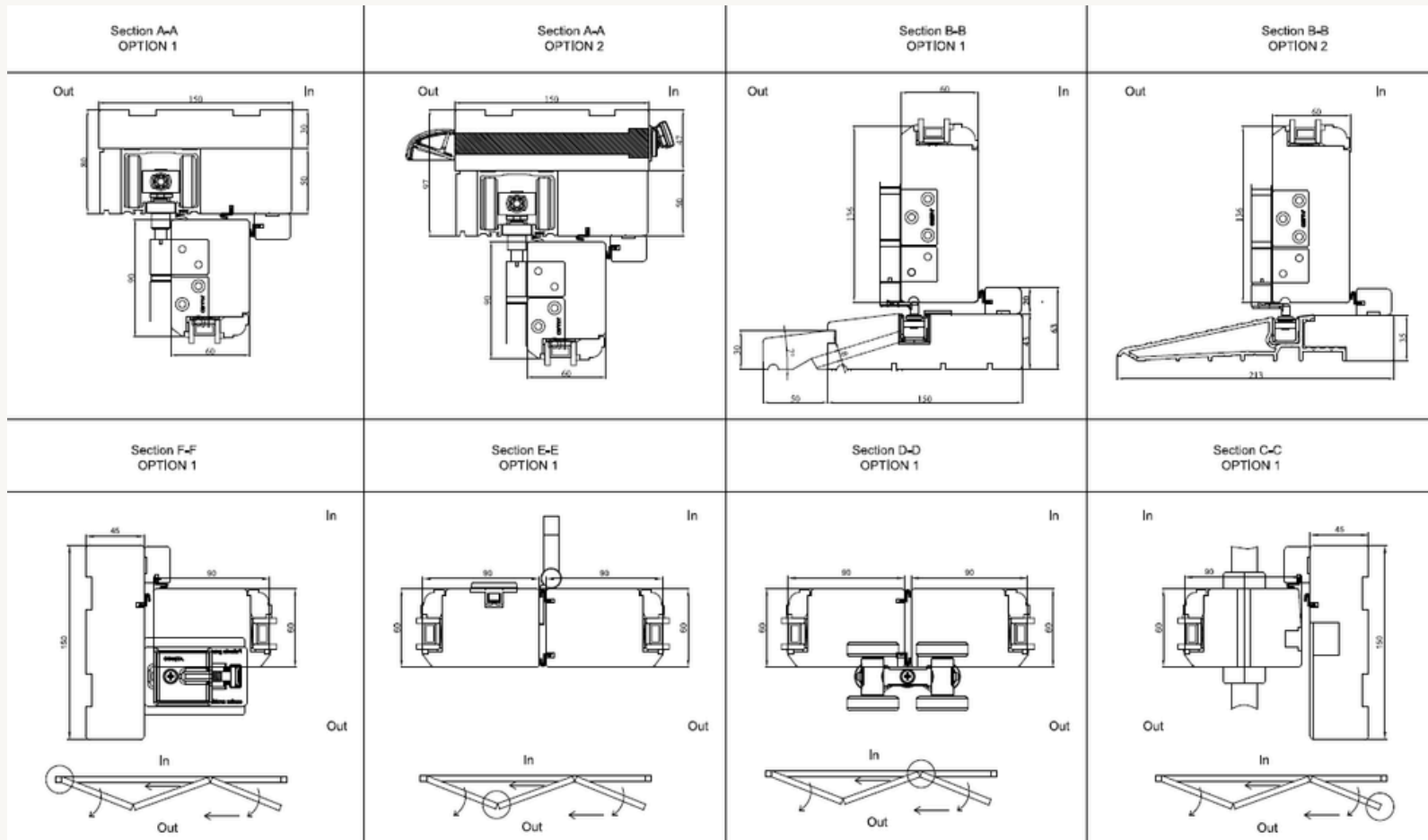

TECHNICAL DRAWINGS

BI -FOLD CENTOR F3

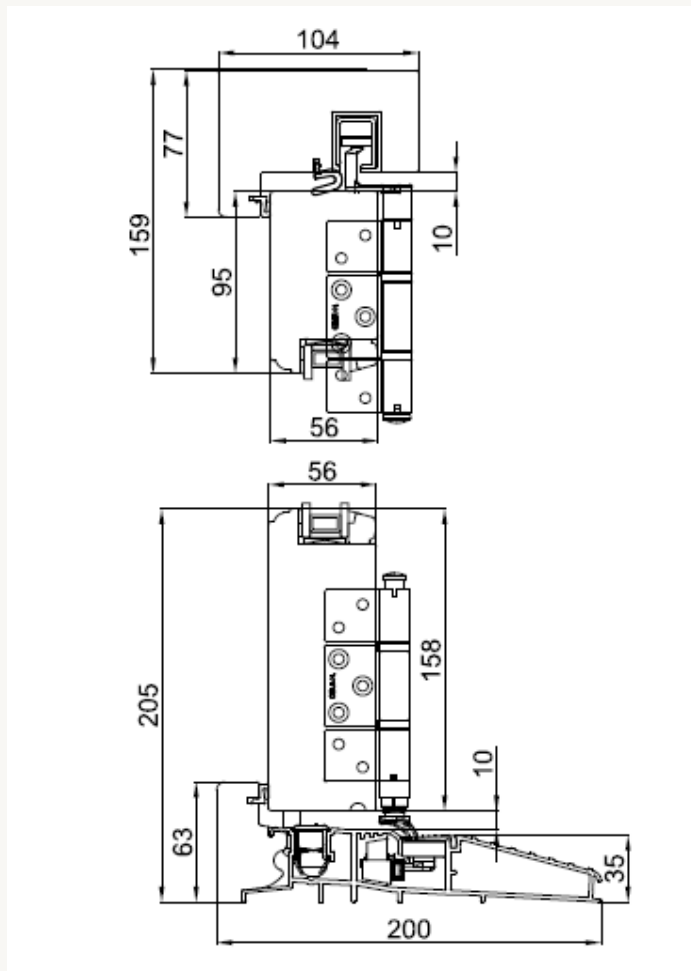

WHAT IS A DIFFERENCE FROM
THE E3 SYSTEM?

- OPTION FOR THINNER FRAME 104MM
AND SASH 56MM
- EXTRA DRAUGHT PROOFING IN
BOTTOM CILL
- WEIGHT OF THE WINGS EMBEDDED IN
THE LOWER SLIDE
- NO OPTION FOR WOODEN CILL

HS SLIDING DOORS

MODERN AND SHOWY
SYSTEM OF SLIDING
DOORS FOR PATIO
AND BALCONY

AVAILABLE ON
EUROPEAN STANDARD
PROFILE 68/78/92MM,
IN MANY OPENING
CONFIGURATIONS



HARDWARE

HANDLES - SIEGIENIA HS300

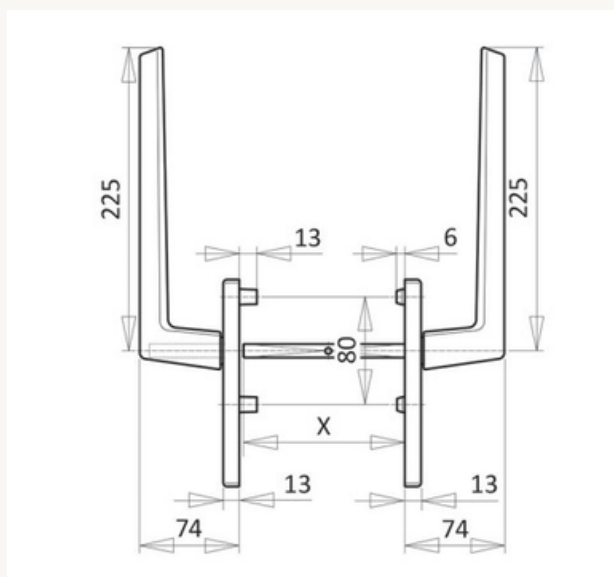

FINISHES:

-WHITE

-SILVER

-BLACK

-ANTIQUÉ BRASS

-DARK BROWN RAL 8022



OPENING OPTIONS

SCHEME A - LEFT

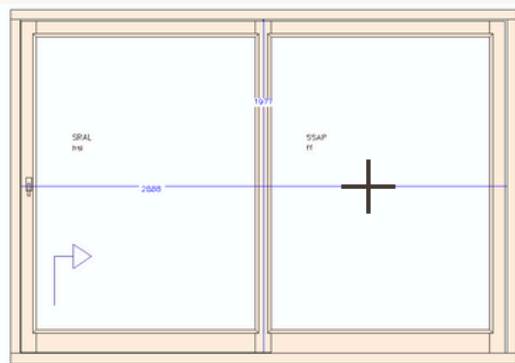

SCHEME A - RIGHT

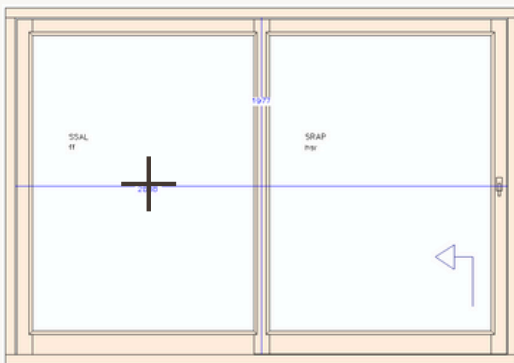

SCHEME D

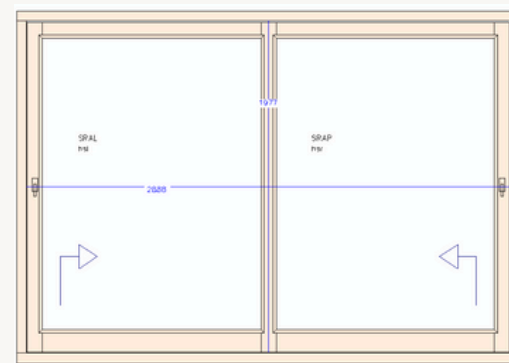

SCHEME E

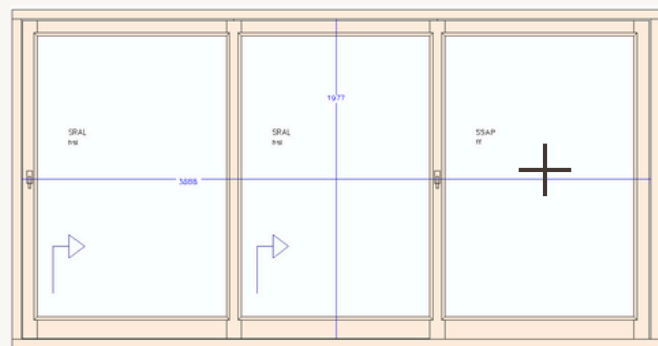

SCHEME C

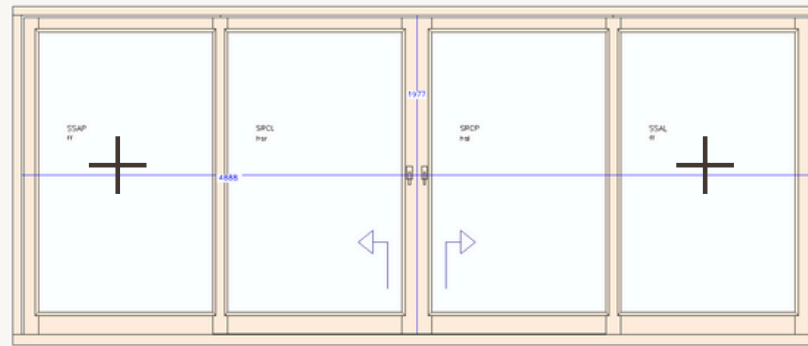

SCHEME F

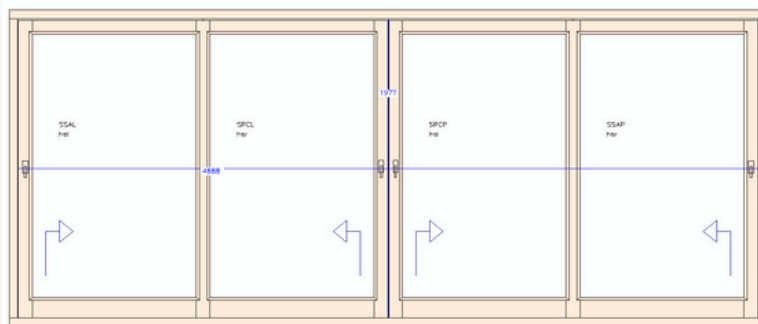

OPENING OPTIONS

SCHEME G1

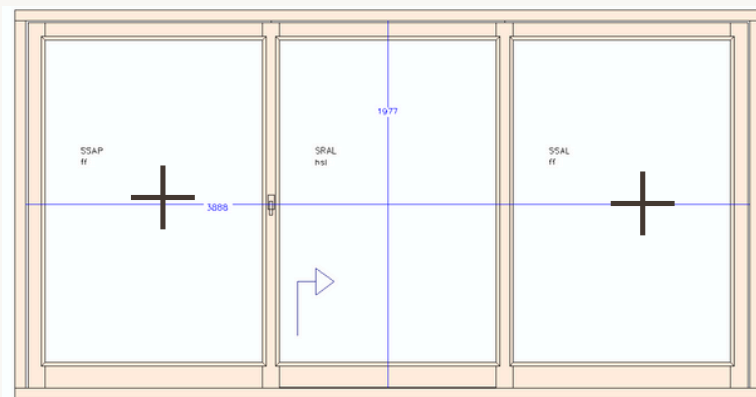

SCHEME H

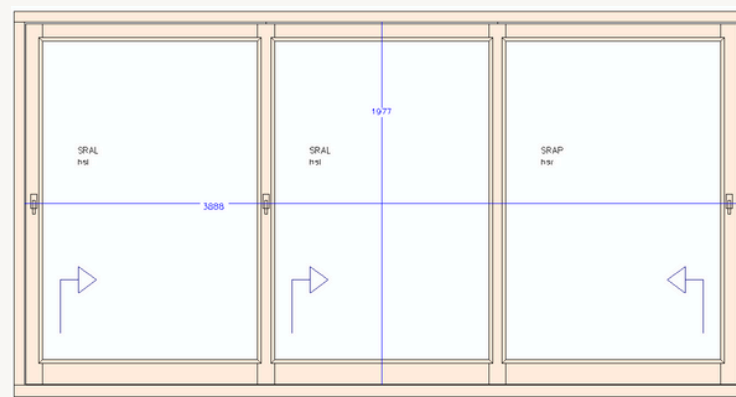

SCHEME K

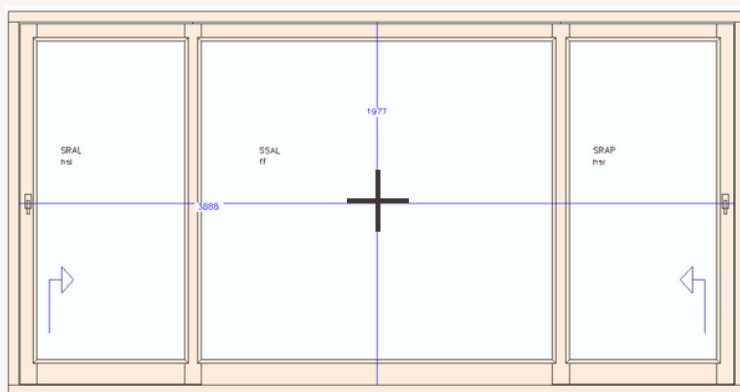

SCHEME L

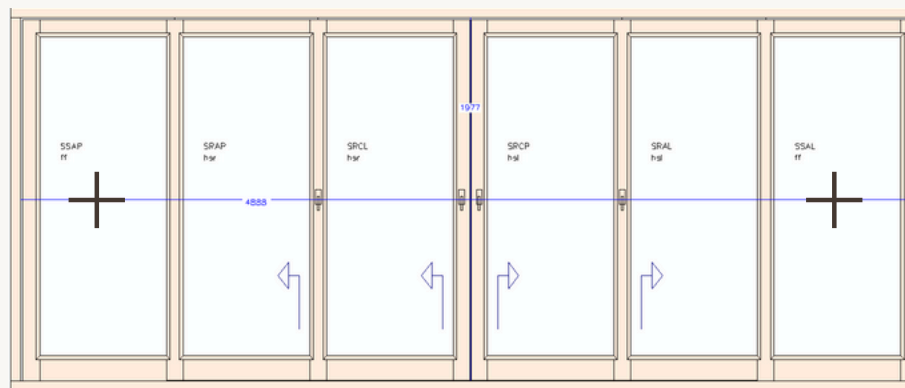

TECHNICAL DRAWINGS

HS - SASH
DEPTH
68/78/92

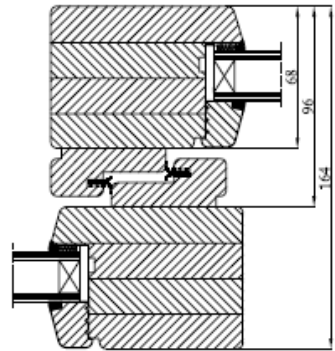

C-C

A-A

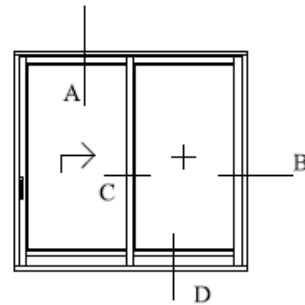
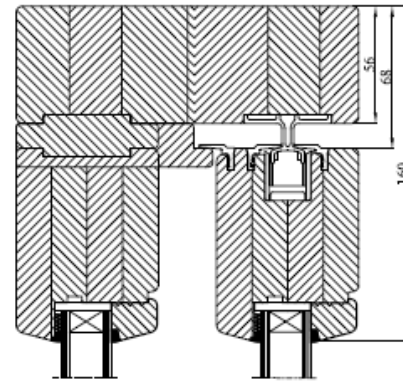

D-D

B-B

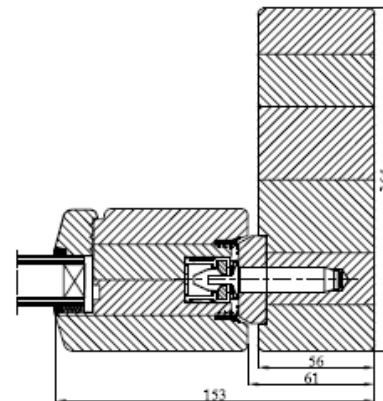
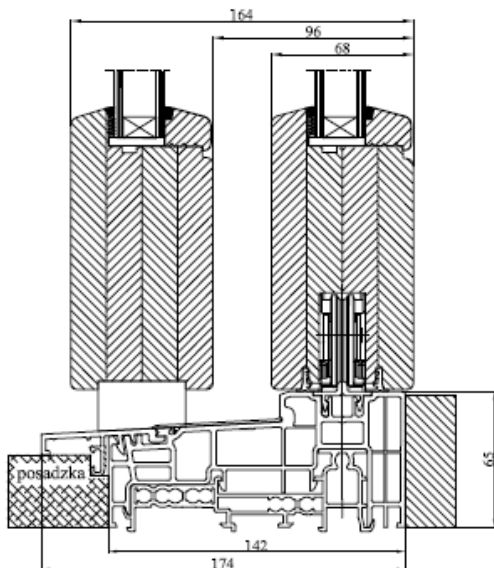

TIMBER CILL
OPTION

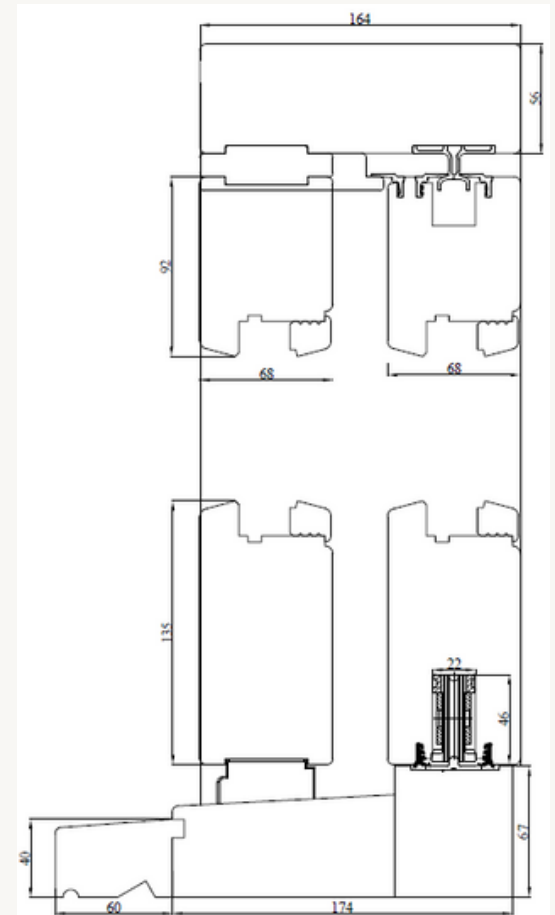

STABLE DOOR

PRACTICAL SOLUTION
THAT ALLOWS THE TOP
HALF OF A DOOR TO
OPEN WHILST THE
LOWER HALF REMAINS
CLOSED

AN ALTERNATIVE
OPTION IS OPENING
BOTH SEGMENTS
TOGETHER AS A SINGLE
DOOR

TRADITIONAL DOORS
WITH A TOUCH OF
MODERNITY AND
ADVANCED
TECHNOLOGY



TECHNICAL DRAWINGS

STABLE DOOR - OPEN IN

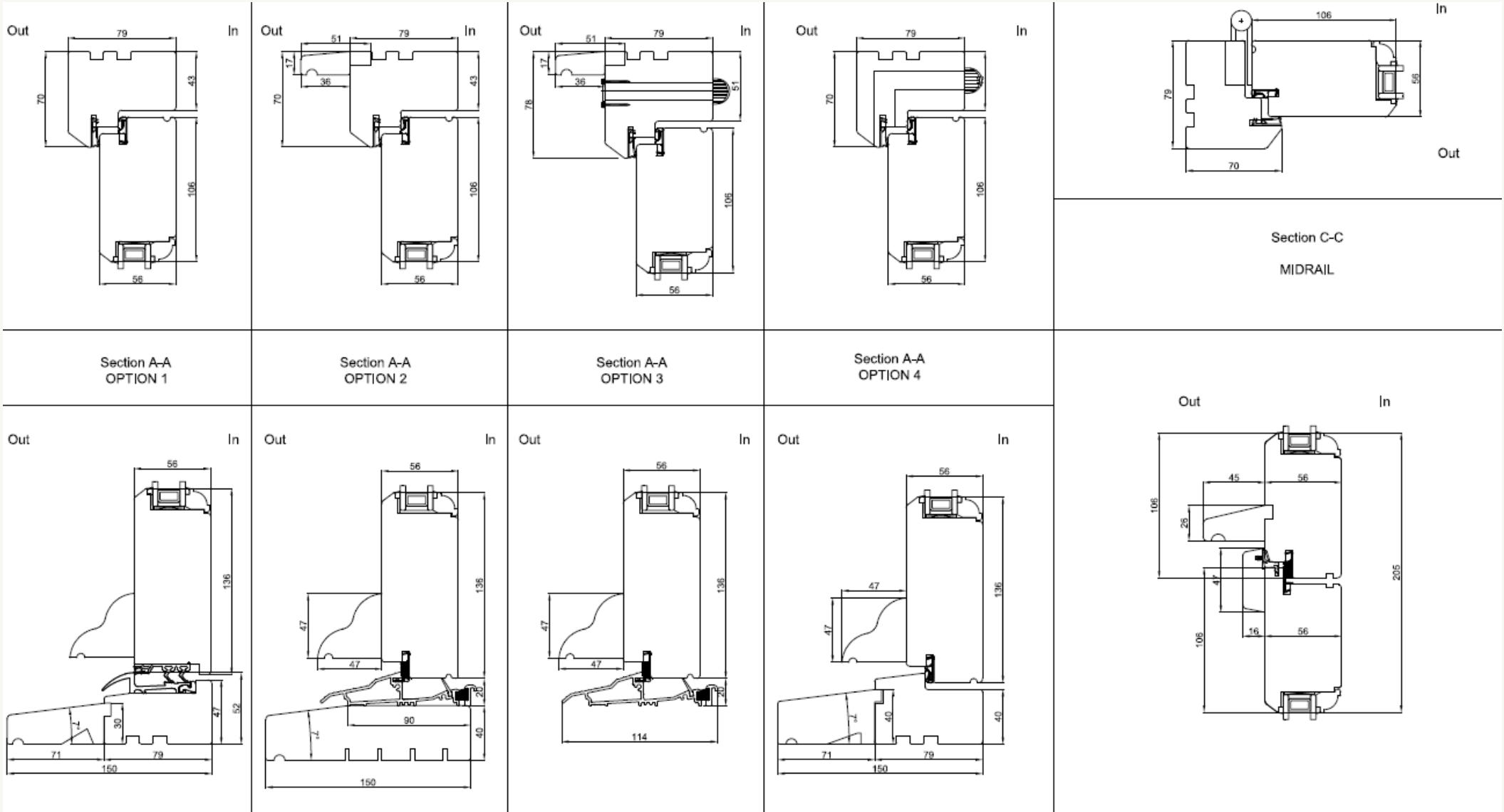

TECHNICAL DRAWINGS

STABLE DOOR - OPEN OUT

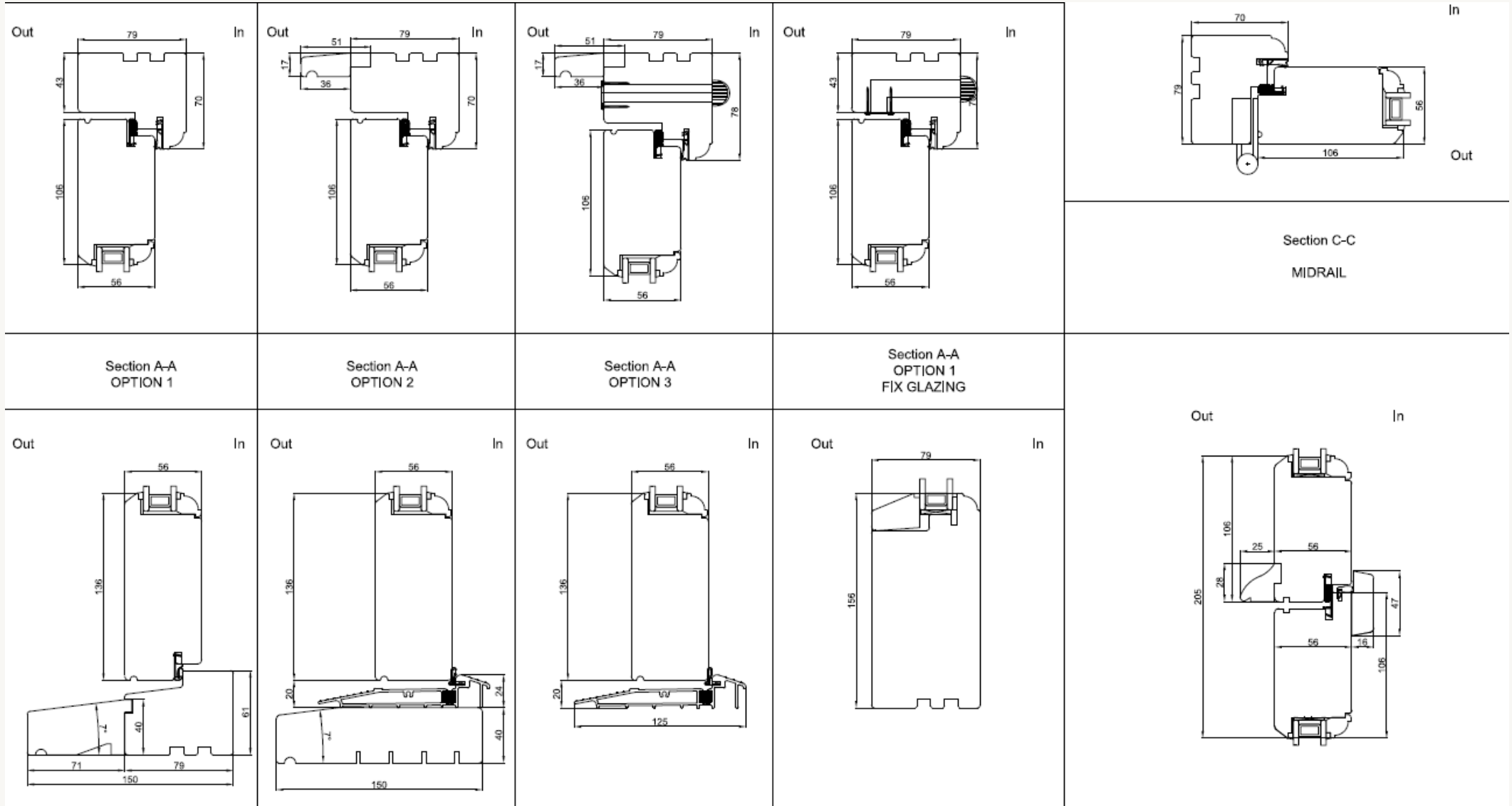

DOORS MADE-TO- MEASURE

CUSTOM-MADE PROJECTS
FOR DEMANDING
CLIENTS ARE OUR
SPECIALITY

WE ARE KNOWN FOR
OUR FLEXIBILITY IN
DOING UNUSUAL ORDERS

IN OUR OFFER, WE HAVE
A HUGE NUMBER OF
VARIANTS TO CHOOSE
FROM AND TECHNOLOGY
ALLOWING US TO
CREATE BESPOKE DOORS



DOORS MADE-TO-MEASURE

FRONT DOORS
WITHOUT
MULTIPOINT
LOCKING SYSTEM,
WITH BANHAM
LOCKS OR ANY
OTHER KIND OF
FASTENER LOCKS,
ARE OUR
SPECIALITY



DOORS MADE-TO- MEASURE

RENOVATION
PROFILES IN
HISTORIC
BUILDINGS,
RESTORATION OF
OLD LIKE-TO-LIKE
PROFILES IS ALSO
ONE OF THE
OPTIONS IN OUR
OFFER



DOORS MADE-TO-MEASURE



DOORS MADE-TO-MEASURE

DRAWINGS

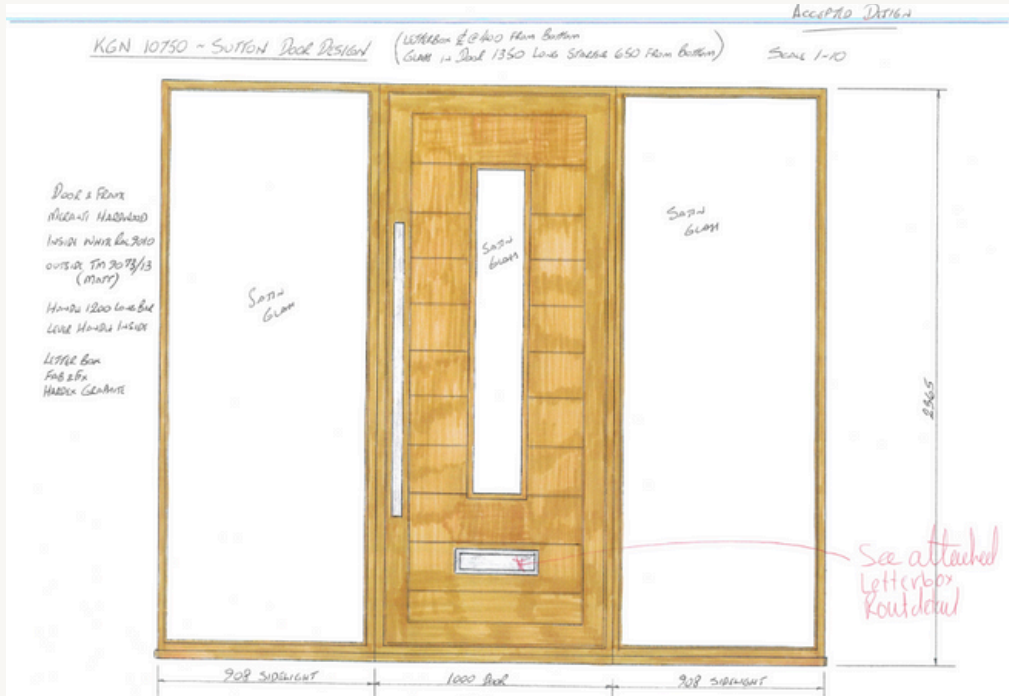

FINISHED DOORS



CASEMENT WINDOWS

HARDWARE

HINGES

FRICTION HINGES (CASEMENT SD AND CASEMENT INLINE)



FOR SIDE HUNG:

- EASY CLEAN
- EASY CLEAN + RESTRICTOR
- EGRESS
- EGRESS EASY CLEAN
- EGRESS + RESTRICTOR



FOR TOP HUNG:

- EASY CLEAN
- EASY CLEAN + RESTRICTOR

HARDWARE

HINGES

BUTT HINGES COASTAL RADIUS CORNER (HQ4R) 102X76MM



FINISHES:

- SATIN STAINLESS
- POLISHED STAINLESS STEEL
- SATIN BRASS
- POLISHED BRASS
- MATT SMOOTH BLACK
- WHITE

BUTT HINGES COASTAL RADIUS CORNER (HY3R) 76X65MM



FINISHES:

- SATIN STAINLESS
- POLISHED STAINLESS STEEL
- SATIN BRASS
- POLISHED BRASS
- MATT SMOOTH BLACK
- WHITE

HARDWARE

HANDLES

MILA PROLINEA



FINISHES:
-POLISHED CHROME
-SATIN CHROME
-POLISHED BRASS
-SMOKEY CHROME
-WHITE
-BLACK

MILA HERITAGE
PEAR DROP

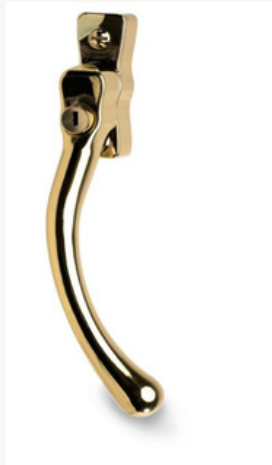

FINISHES:
-POLISHED CHROME
-SATIN CHROME
-POLISHED BRASS
-WHITE
-MATT BLACK
-HERITAGE BLACK
-PEWTER PATINA
-ANTIQUE BRONZE
-HERITAGE PEWTER

MILA HERITAGE
MONKEY TAIL

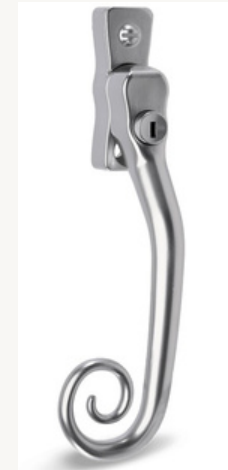

FINISHES:
-POLISHED CHROME
-SATIN CHROME
-POLISHED BRASS
-WHITE
-MATT BLACK
-HERITAGE BLACK
-PEWTER PATINA
-ANTIQUE BRONZE
-HERITAGE PEWTER

HARDWARE

TRICKLE VENTS

TITON XS13/S13

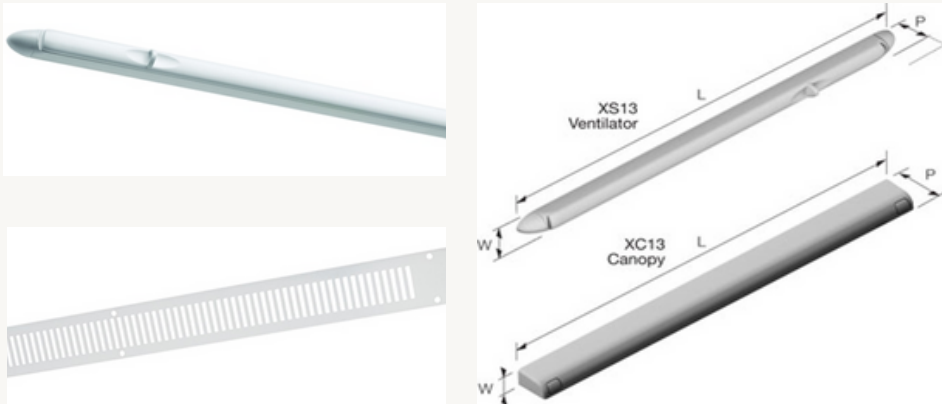

FINISHES:
-TOFFIE
-BROWN
-BLACK
-BRIGHT WHITE

TRYKVENT 389/283

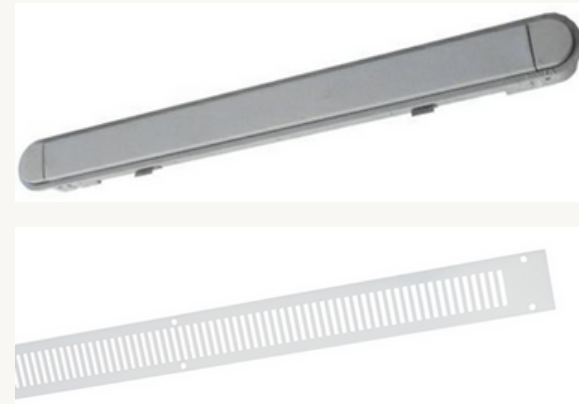

FINISHES:
-WHITE
-BROWN
-GRAY

HARDWARE

TRICKLE VENTS

TITON XSI3/SI3 AND TRYKVENT 389/283

AVAILABLE OPTIONS :

INSTALLED IN FRAME

- WITH FLAT GRILLE AND WOODEN HEAD DRIP
- WITH CANOPY FROM OUTSIDE
- HIDDEN (NO VISIBLE VENT FROM OUTSIDE) - AVAILABLE ONLY IN CASEMENT INLINE FLUSH 79MM

INSTALLED IN SASH:

- WITH CANOPY FROM OUTSIDE

FLUSH CASEMENT INLINE

CASEMENT INLINE
(FLUSH) WITH
FRAME DEPTH
79MM AND SASH
56MM

ALLOW FOR USING
DOUBLE GLAZED
UNITS 24/25MM OR
FOR SINGLE GLASS
PANE



TECHNICAL DRAWINGS

FLUSH CASEMENT INLINE

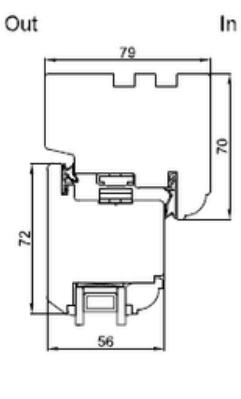
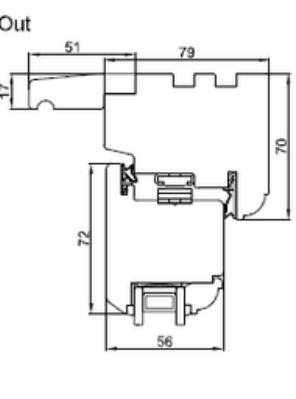
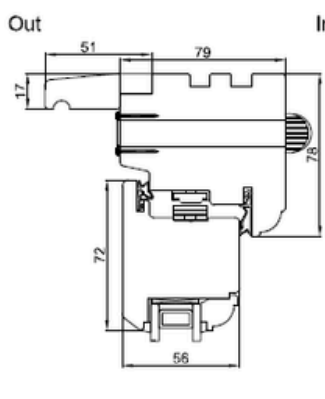
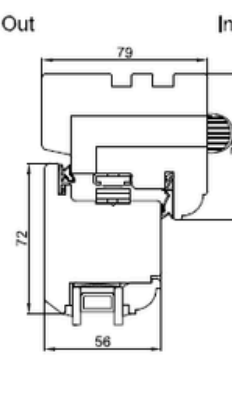
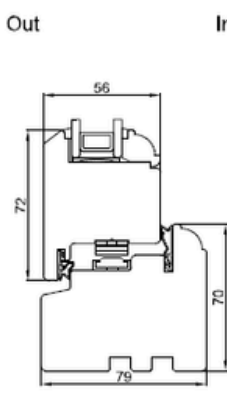
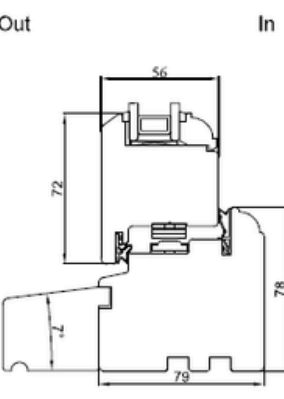
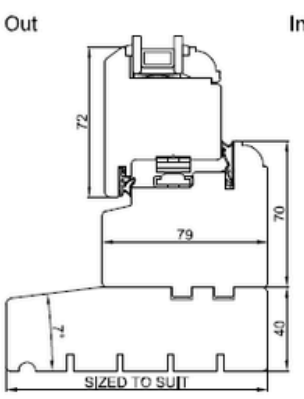
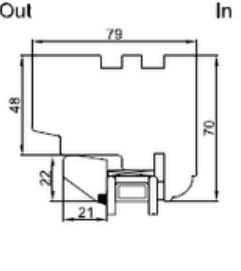
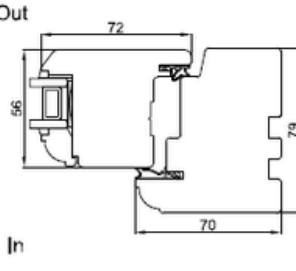
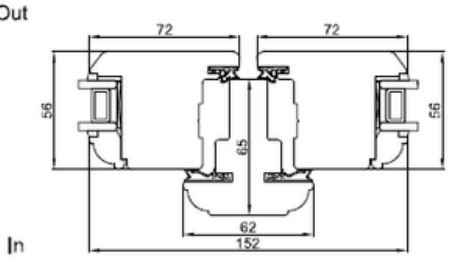
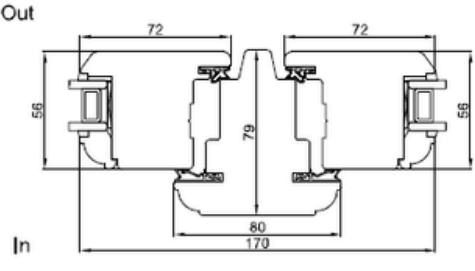
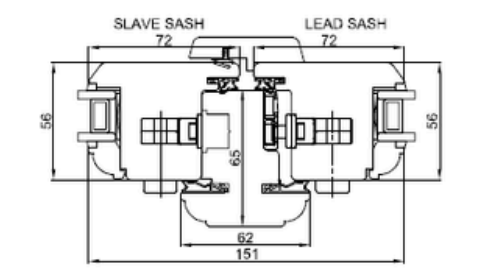
Section A-A OPTION 1	Section A-A OPTION 2	Section A-A OPTION 3	Section A-A OPTION 4	Section B-B OPTION 1	Section B-B OPTION 2	Section B-B OPTION 3
<p>Out In</p> 	<p>Out In</p> 	<p>Out In</p> 	<p>Out In</p> 	<p>Out In</p> 	<p>Out In</p> 	<p>Out In</p> 
Section G-G FIX GLAZING	Section C-C	Section D-D Solid mullion OPTION 1		Section D-D Solid mullion OPTION 2		Section D-D flying mullion OPTION 3
<p>Out In</p> 	<p>Out In</p> 	<p>Out In</p> 		<p>Out In</p> 		<p>Out In</p> 

CASEMENT INLINE SD

PROFILE WITH THICKER
FRAME 92MM AND SASH
60MM

ALLOWS TO USE PEG
STAYS, FASTENER
HANDLES AND BUTT
HINGES

DEDICATED TO
TRADITIONAL BUILDINGS
WHERE IT IS
IMPORTANT TO
PRESERVE ORIGINAL
SYSTEMS AND PROFILES



HARDWARE

THE SAME FITTINGS ARE AVAILABLE AS IN THE FLUSH CASEMENT INLINE 79MM

ADDITIONALLY CAN BE USED:

FASTENER HANDLES FROM ANVIL

ANVIL CAST
MONKEYTAIL



ANVIL CAST
PEARDROP



PEG STAYS FROM ANVIL

CAST PEARDROP



CAST MONKEYTAIL



TECHNICAL DRAWINGS

FLUSH CASEMENT INLINE SD

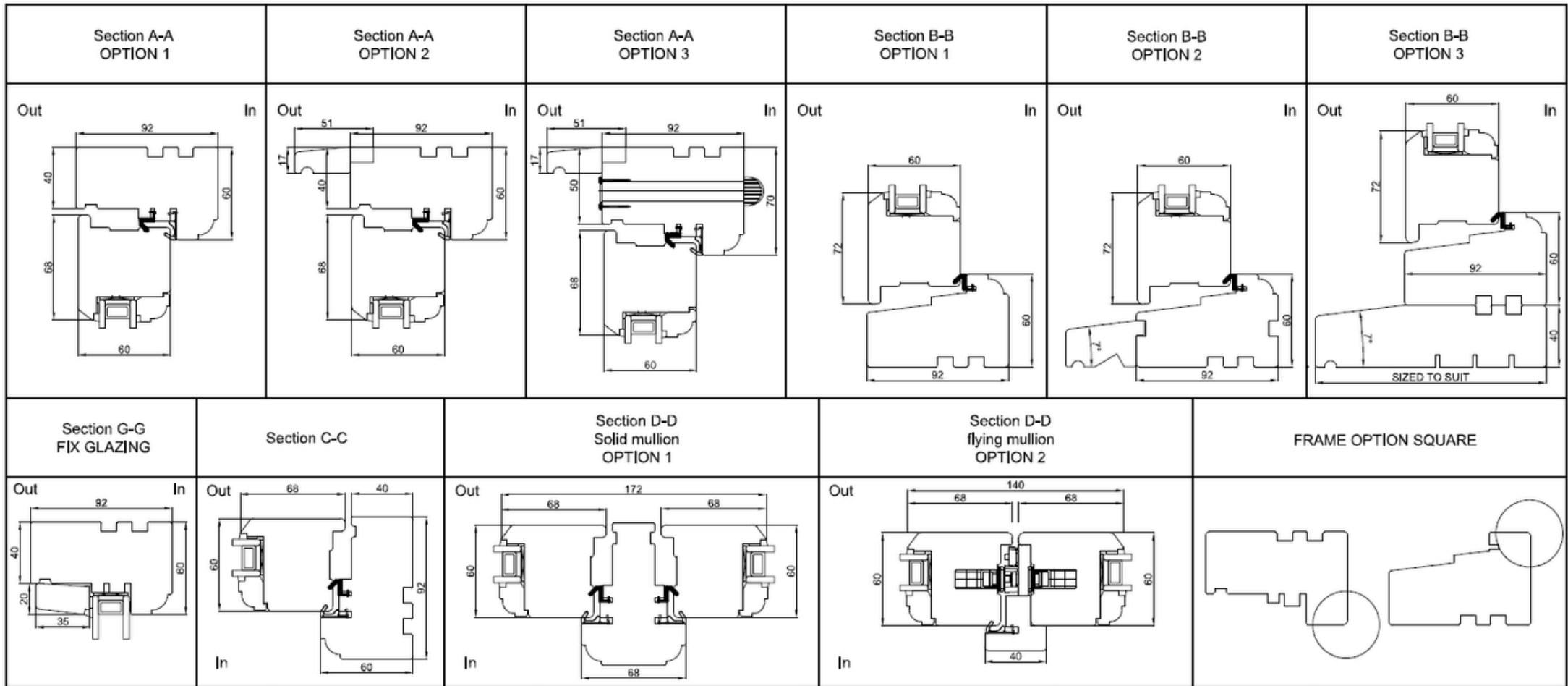

CASEMENT
STORMPROOF
(LIPPED)

TRADITIONAL
WINDOW PROFILE
WHERE THE FRAME
IS NOT FLUSH WITH
SASH

HEAD DRIPS ARE
USED AS A
STANDARD TO
PREVENT LEAKAGE
OF WATER ONTO
THE SASH

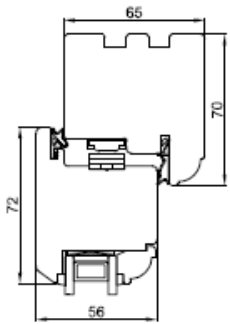
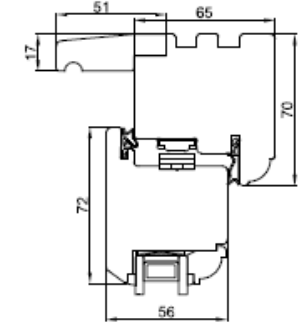
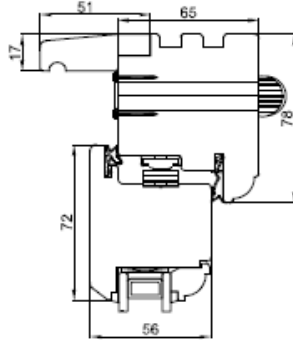
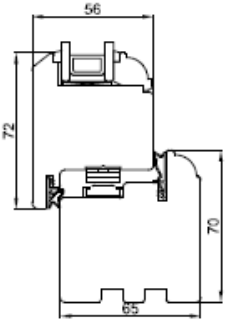
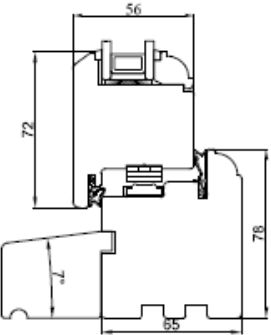
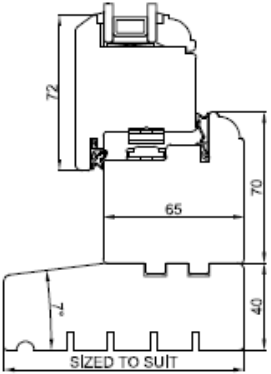
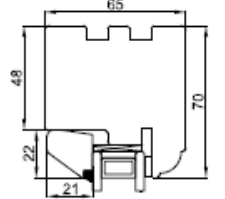
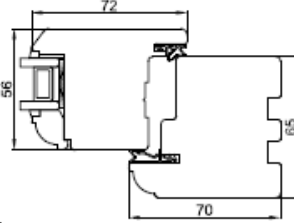
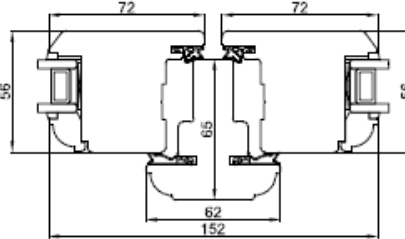
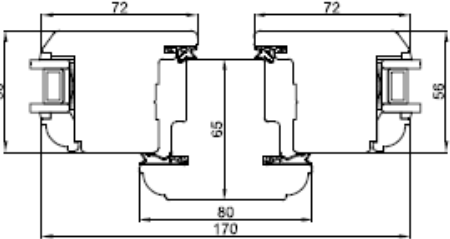
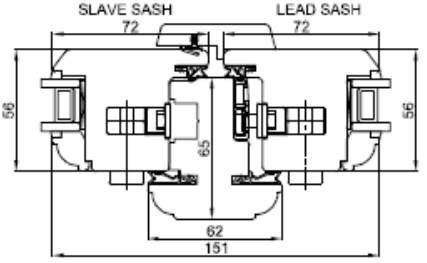

TECHNICAL DRAWINGS

<p>Section A-A OPTION 1</p>	<p>Section A-A OPTION 2</p>	<p>Section A-A OPTION 3</p>	<p>Section B-B OPTION 1</p>	<p>Section B-B OPTION 2</p>	<p>Section B-B OPTION 3</p>	
<p>Out In</p> 	<p>Out In</p> 	<p>Out In</p> 	<p>Out In</p> 	<p>Out In</p> 	<p>Out In</p>  <p>SIZED TO SUIT</p>	
<p>Section G-G FIX GLAZING</p>	<p>Section C-C</p>	<p>Section D-D Solid mullion OPTION 1</p>		<p>Section D-D Solid mullion OPTION 2</p>		<p>Section D-D flying mullion OPTION 3</p>
<p>Out In</p> 	<p>Out In</p> 	<p>Out In</p> 		<p>Out In</p> 		<p>SLAVE SASH LEAD SASH</p> 

CUSTOM PROJECTS

CASEMENT
WINDOWS CAN BE
MADE WITH MANY
CONFIGURATIONS
OF BARS AND IN
MANY DIFEFRENT
SHAPES - ARCHES,
TRIANGLES,
TRAPEZOIDS AND
CIRCLES



SLIDING SASH WINDOWS

HARDWARE

ALL HARDWARE IS FROM MIGHTON UK

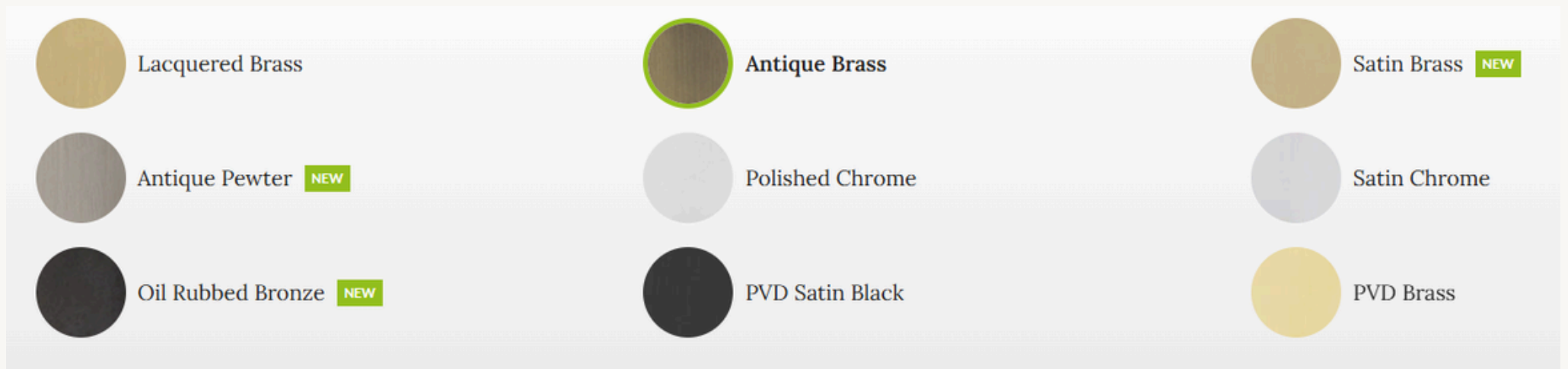

NON-STANDARD FINISHES:

-WHITE

-SATIN NICKEL

THE AVAILABILITY OF COLOURS MAY VARY AND SHOULD BE CONFIRMED WITH MIGHTON EACH TIME

HARDWARE

RING SASH EYE



D-HANDLE



HOOK LIFTS



HARDWARE

SLIDING SASH LOCKS



MINI BRIGHTON FASTENER
- LOCKING WITH KEY
- NON-LOCKING

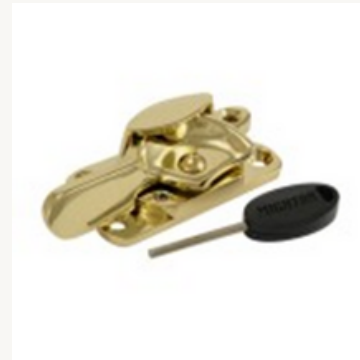

FITCH FASTENER / HERITAGE FASTENER
- LOCKING WITH KEY
- NON-LOCKING



MODERN
- LOCKING WITH KEY
- NON-LOCKING



HARDWARE

SLIDING SASH LOCKS



HOOK (PLAIN KNOB)
- LOCKING WITH KEY



HOOK (REEDED KNOB)
- LOCKING WITH KEY



HOOK (CERAMIC KNOB)
- LOCKING WITH KEY



HARDWARE

SASH RESTRICTORS



ANGEL
VENTLOCK



MIGSTOP



VENT LOCK
LOCKING



PUSH
VENTLOCK



MINI LOCKS



HARDWARE

SASH PULLEYS

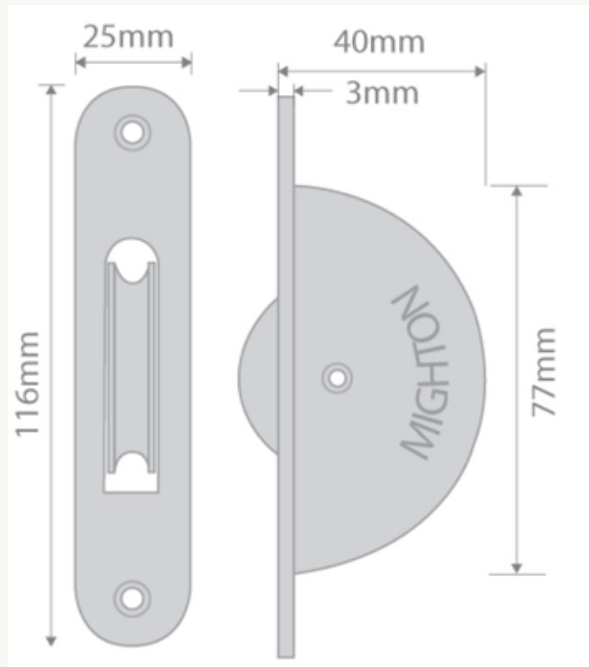

SASH SPRINGS

FINISHES:

- WHITE
- BROWN
- GREY
- CREAM

CALDWELL
SOLUTIONS THAT SET NEW STANDARDS
Telephone 024 7643 7900

Spring Balance Model Options

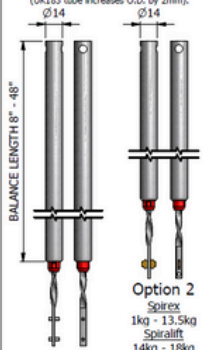
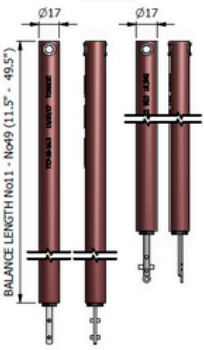
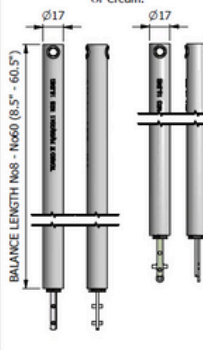
Spiral Balance.	Ultralift (UL6) Balance.	Torso II Balance.
Aluminium Tube Mill Finish, Or PVC-U Tube Brown Or White (UK103 tube increases O.D. by 2mm).	PVC-U Tube White, Brown, Grey Or Cream.	PVC-U Tube White, Brown, Grey Or Cream.
		
Option 1 Alumatilt 1kg - 13.5kg Alumatilt Heavyduty 14kg - 18kg For tilt in sash.	Option 1 2 pins for tilt in sash. Standard component.	Option 1 2 Pins for tilt in sash.
Option 2 Spiorex 1kg - 13.5kg Spiralift 14kg - 18kg For non tilting.	Option 2 For non tilt sash. Add cruciform bracket UK201	Option 2 For non tilt sash. Add cruciform bracket UK201

HARDWARE

TRICKLE VENTS

TITON XS16

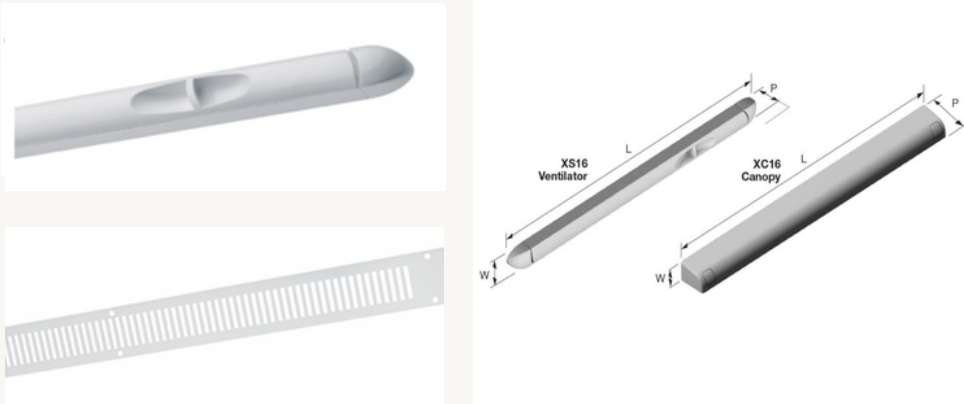

FINISHES:
-TOFFIE
-BROWN
-BLACK
-BRIGHT WHITE

TRYKVENT 389/283

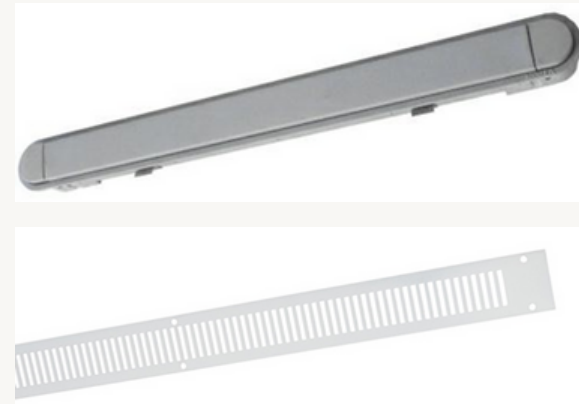

FINISHES:
-WHITE
-BROWN
-GRAY

HARDWARE

TRICKLE VENTS

TITON XS16 AND TRYKVENT 389/283

AVAILABLE OPTIONS :

INSTALLED IN FRAME

- STANDARD WITH FLAT GRILLE - CUTTED TOP SASH RAIL
- HIDDEN WITH FLAT GRILL - CUTTED TOP BOX

INSTALLED IN SASH:

- WITH CANOPY FROM OUTSIDE

TYPES OF SASH HORNS

HORN 1

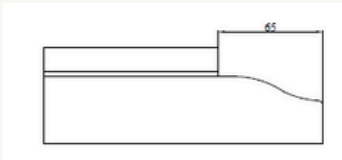

HORN 2

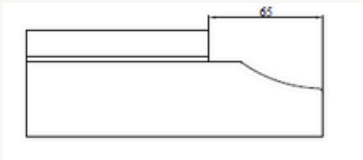

HORN 3

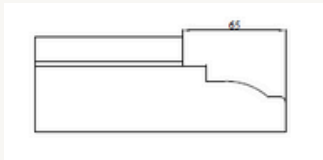

HORN 4

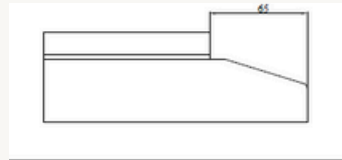

HORN 5

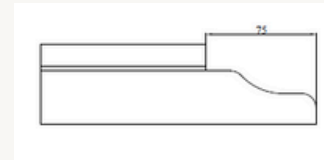

HORN 6

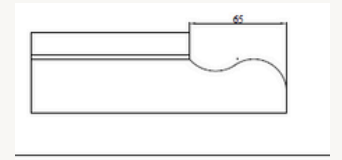

HORN 7

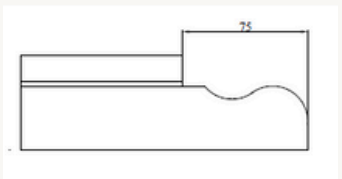

HORN 8

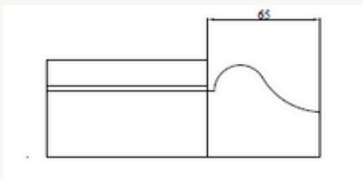

HORN 9

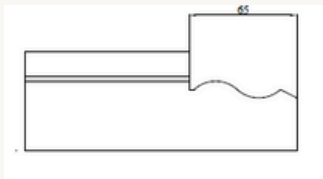

HORN 10

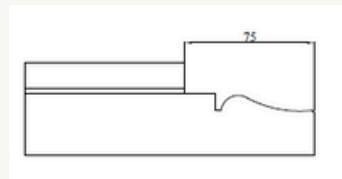

HORN 11

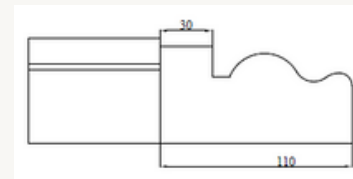

HORN 12

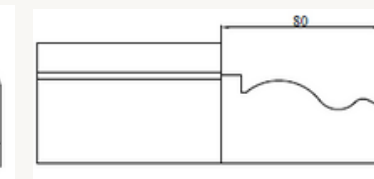

SLIDING SASH CORDS & WEIGHTS

TRADITIONAL
VERTICAL SLIDING SASH
WINDOW WITH CORDS
& WEIGHTS

COMBINES CLASSIC
DESIGN WITH MODERN
TECHNOLOGY AND
GOOD THERMAL
PERFORMANCE

IT COMES IN THREE
SASH BOX THICKNESSES:

165/56

150/50

145/44

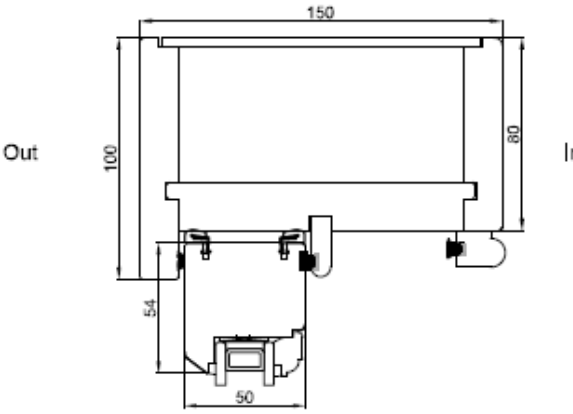
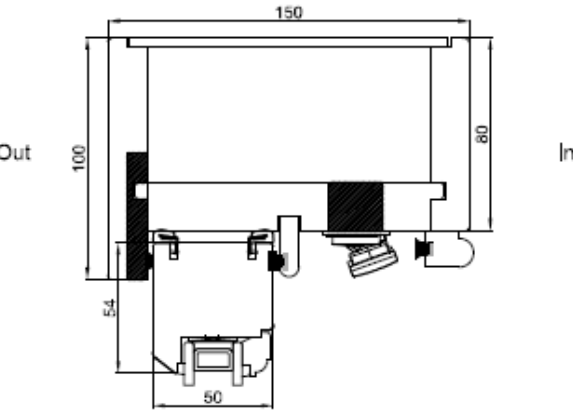
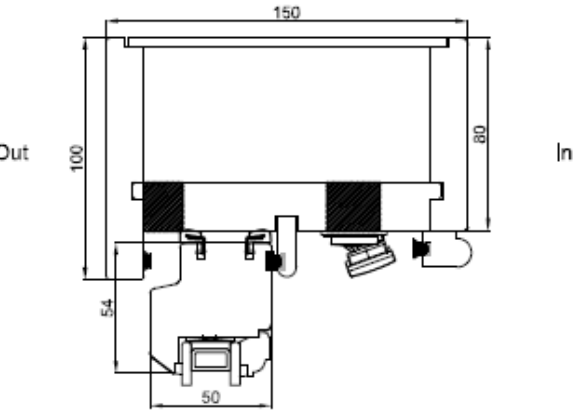
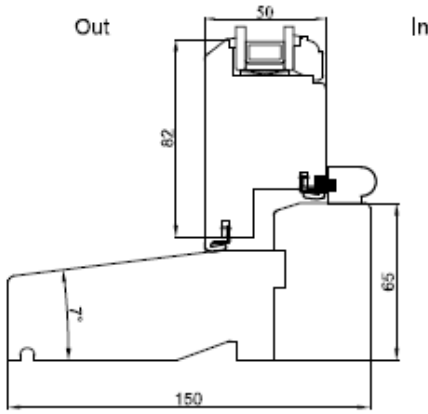
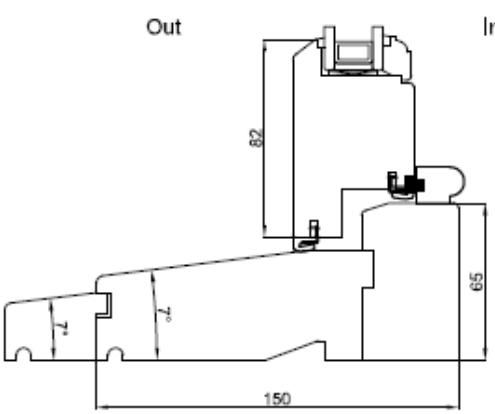
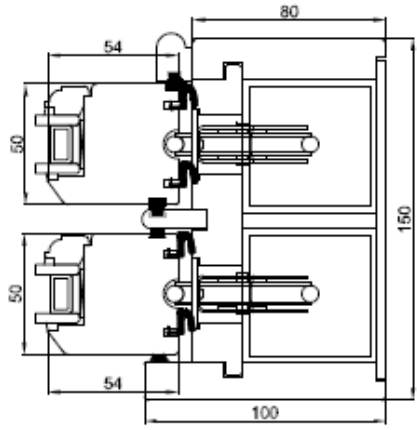

TECHNICAL DRAWINGS

Section A-A OPTION 1	Section A-A OPTION 2 - VENTILATION - HIDDEN	Section A-A OPTION 2 - VENTILATION - STANDARD
 <p>Out</p> <p>In</p>	 <p>Out</p> <p>In</p>	 <p>In</p> <p>Out</p>
Section B-B OPTION 1	Section B-B OPTION 2	Section C-C OPTION 1
 <p>Out</p> <p>In</p>	 <p>Out</p> <p>In</p>	 <p>80</p> <p>150</p> <p>54</p> <p>50</p> <p>54</p> <p>100</p>

SLIDING SASH SPIRAL BALANCE

MODERN AND
CONTEMPORARY
OPENING SOLUTION

SUITABLE FOR LARGE
AND HEAVY SASHES
AND WHEN BOXES NEED
TO BE SLIMMER

IT COMES IN THREE
FRAME THICKNESSES:

165/56

150/50

145/44

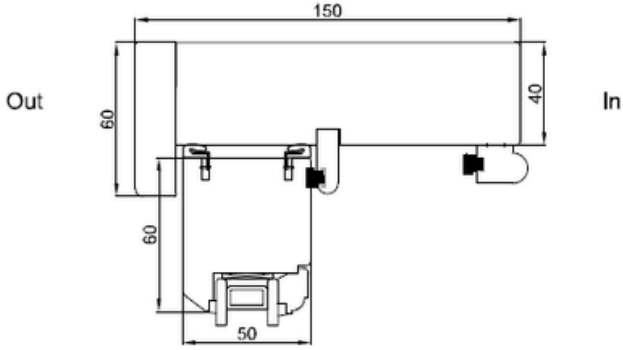
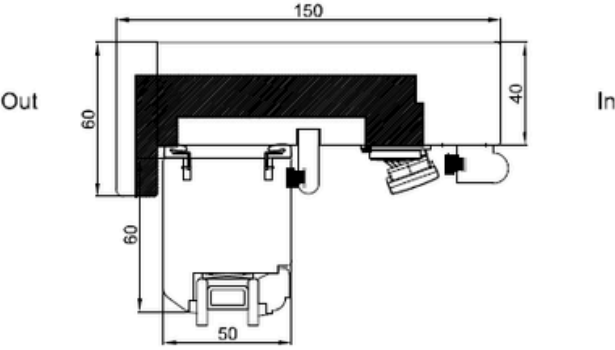
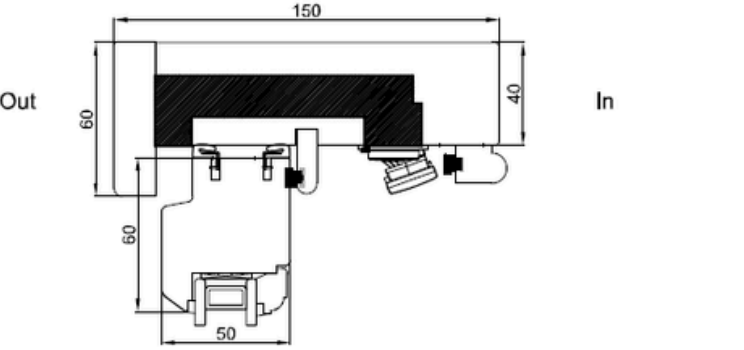
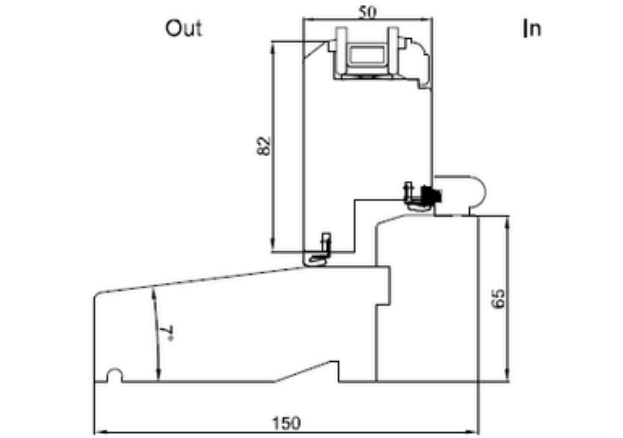
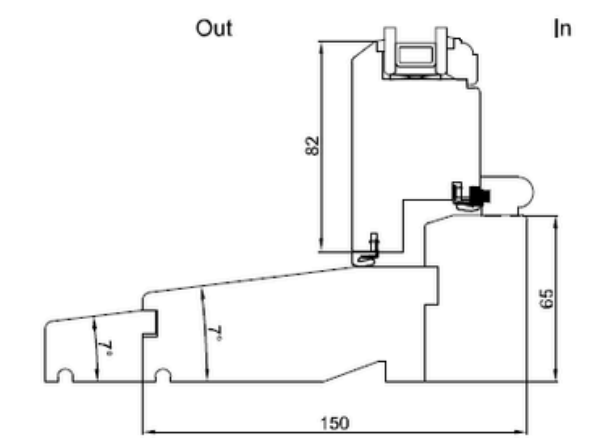
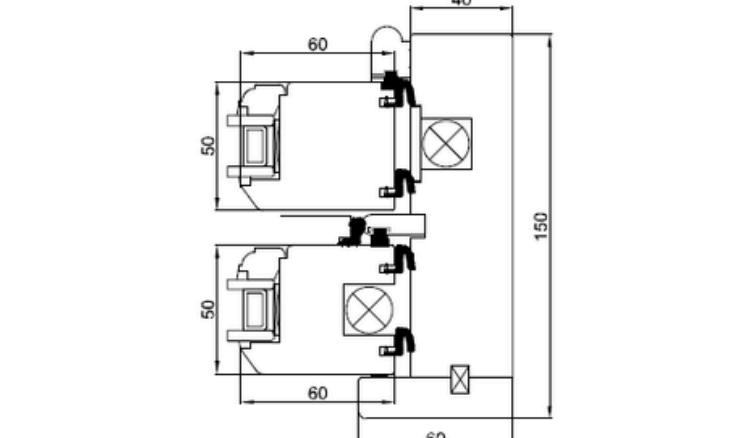

TECHNICAL DRAWINGS

Section A-A OPTION 1	Section A-A OPTION 2 - VENTILATION - HIDDEN	Section A-A OPTION 2 - VENTILATION - STANDARD
		
Section B-B OPTION 1	Section B-B OPTION 2	Section C-C OPTION 1
		

YORKSHIRE

HORIZONTAL
SLIDING SASH
WINDOW WITH
SPIRAL BALANCE
OPENING SYSTEM

WINDOW BENEFITS
FROM ALL THE
FEATURES FOUND IN
TRADITIONAL
SLIDING SASH
WINDOW

FRAME DEPTH
150MM



TECHNICAL DRAWINGS

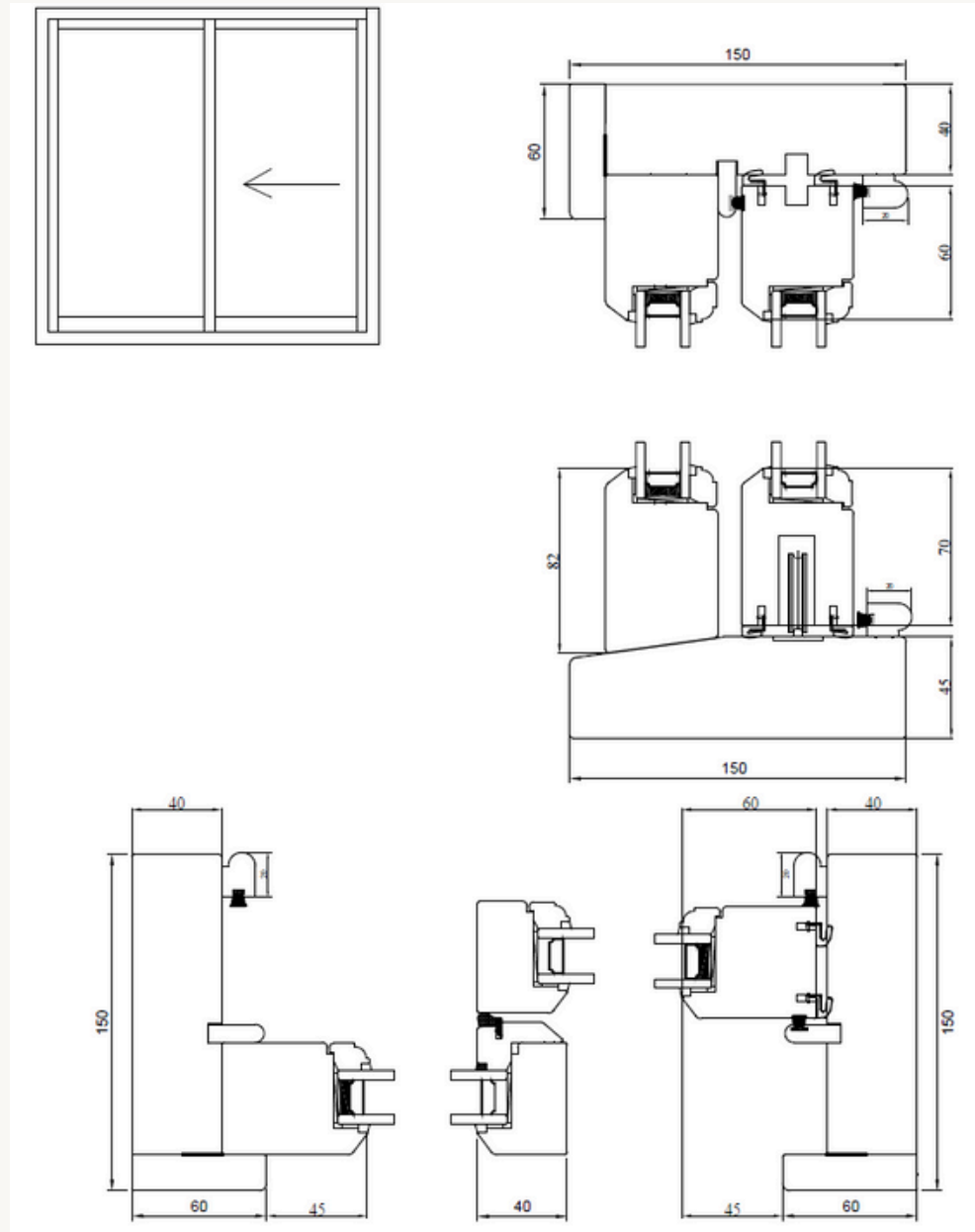

TILT&TURN EUROPEAN PROFILES
“STANDARD LINE”

STANDARD 68/78/92

EUROPEAN PROFILE
OPENING TO THE
INSIDE

ALLOWS FOR FEW
OPENING OPTIONS:
TILT&TURN, TILT
ONLY, TURN ONLY,
PIVOT OR FOR
BALCONY WINDOWS

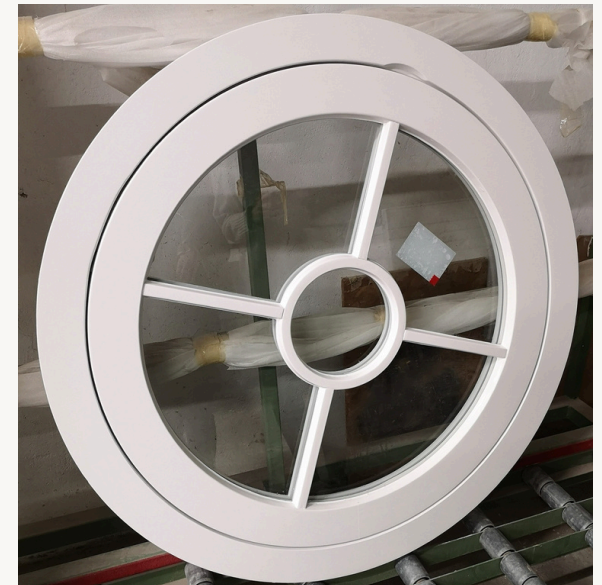

HARDWARE

HANDLE HOPPE

TYPE: NEW YORK SECUSTIK 100 WITH KEY
OR NEW YORK SECUSTIK NON LOCKING

OTHER TYPES FOR REQUEST

FINISHES:

- SILVER
- POLISHED BRASS
- OLD GOLD
- WHITE
- BROWN



TECHNICAL DRAWINGS

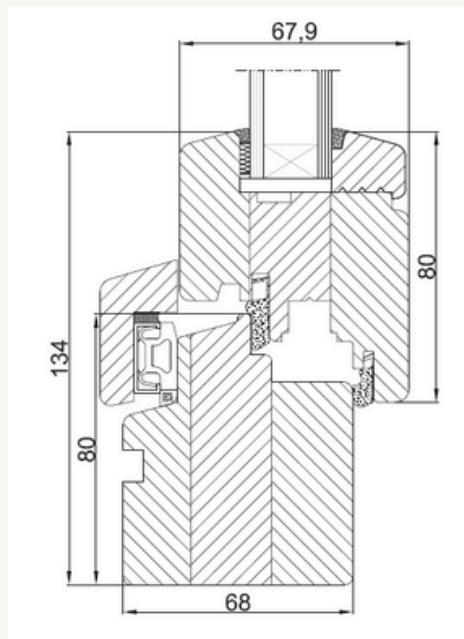
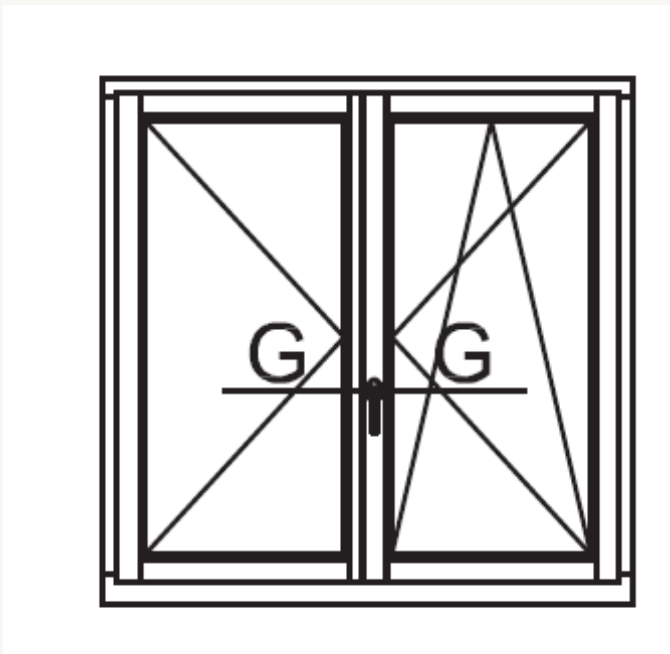
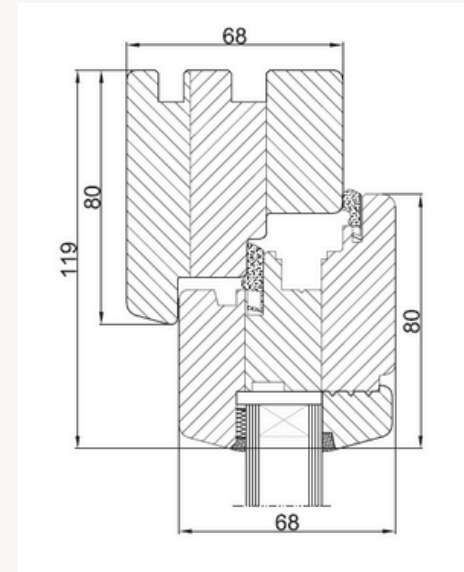
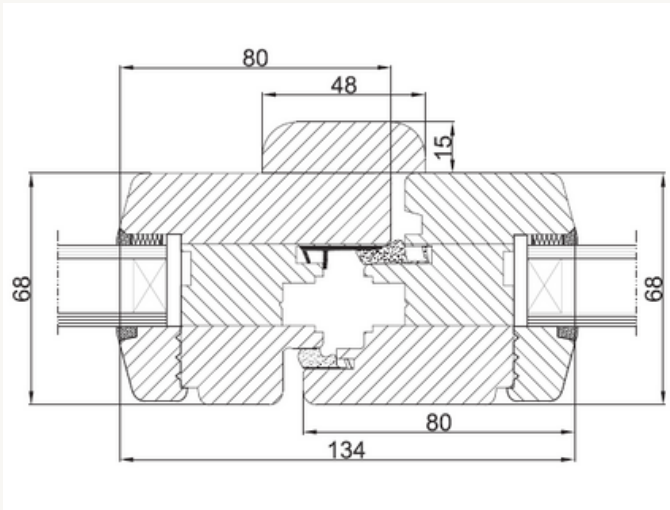

PUTTY IMITATION

PUTTY IMITATION

RESTORATION PROFILE FOR
SLIDING SASH WINDOWS,
CASEMENTS AND FLUSH
DOORS

IT IS AN INNOVATIVE
SOLUTION – TRADITIONAL
PUTTY IS SUBSTITUTED WITH
WOODEN GLAZING BEADS IN
THE SAME SHAPE - THAT
IMITATES PUTTY FROM THE
OUTSIDE

IT IS ESPECIALLY
RECOMMENDED FOR LISTED
BUILDINGS OR TRADITIONAL
PROPERTIES



PUTTY IMITATION

TECHNICAL DETAILS:

- EXTERNALLY GLAZED - WITH TIMBER BEAD IN PUTTY SHAPE
- GLAZING WITH SINGLE GLASS PANE 4-6MM OR SLIMLINE GLASS UNITS WITH KRYPTON GAS 12MM (4/4KR/4), 14MM (4/6KR/4), 16MM (4/8KR/4)
- OPTION FOR ARGON GAS
- ONLY STRUCTURAL SOLID BARS 22MM/ 24MM
- NO OPTION FOR FIXED SECTIONS (GLAZED DIRECTLY IN FRAME) - ONLY OPENING OR DUMMY SASH
- DEDICATED PROFILES: SS C&W 145/44, CASEMENT INLINE SD AND FLUSH DOOR SD



TECHNICAL DRAWINGS

CASEMENT SD WITH
PUTTY IMITATION

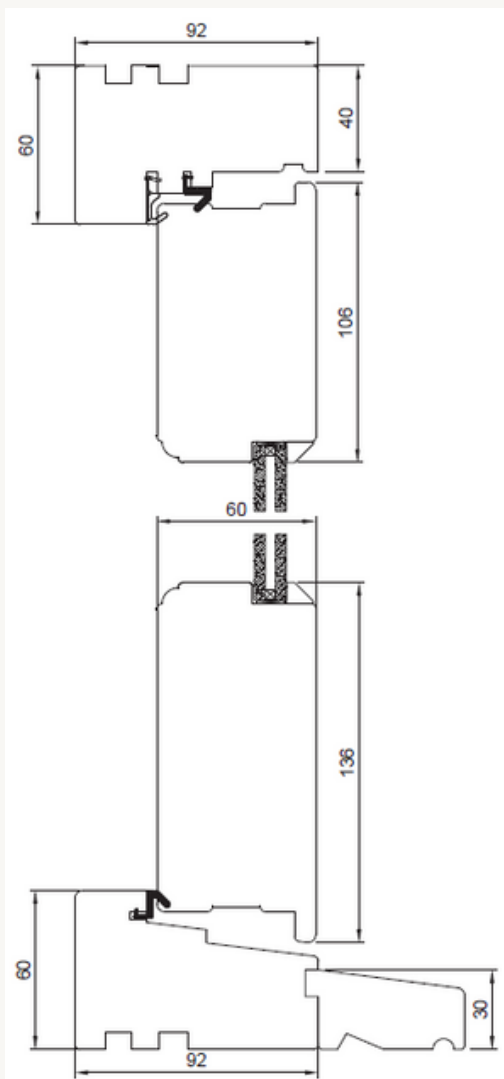

SLIDING SASH 145/44 WITH
PUTTY IMITATION

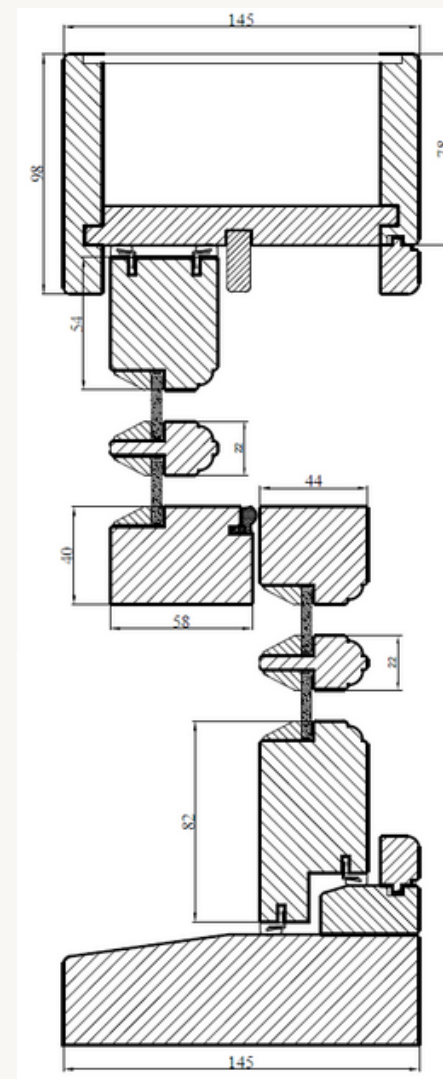

ALU-CLAD SYSTEMS

SLIDING SASH ALU-CLAD

INNOVATIVE AND
TECHNOLOGICALLY
ADVANCED SOLUTION
THAT COMBINES THE
TRADITION AND CLASS
OF SLIDING SASH
WINDOWS WITH SAFETY
AND PROTECTION FROM
THE OUTSIDE

ESPECIALLY
RECOMMENDED FOR
SEASIDE AREAS, EXPOSED
TO HIGH HUMIDITY AND
SALINITY

AVAILABLE WITH
SPRING-BALANCED
OPENING SYSTEM



TECHNICAL DRAWINGS

DOUBLE GLAZED

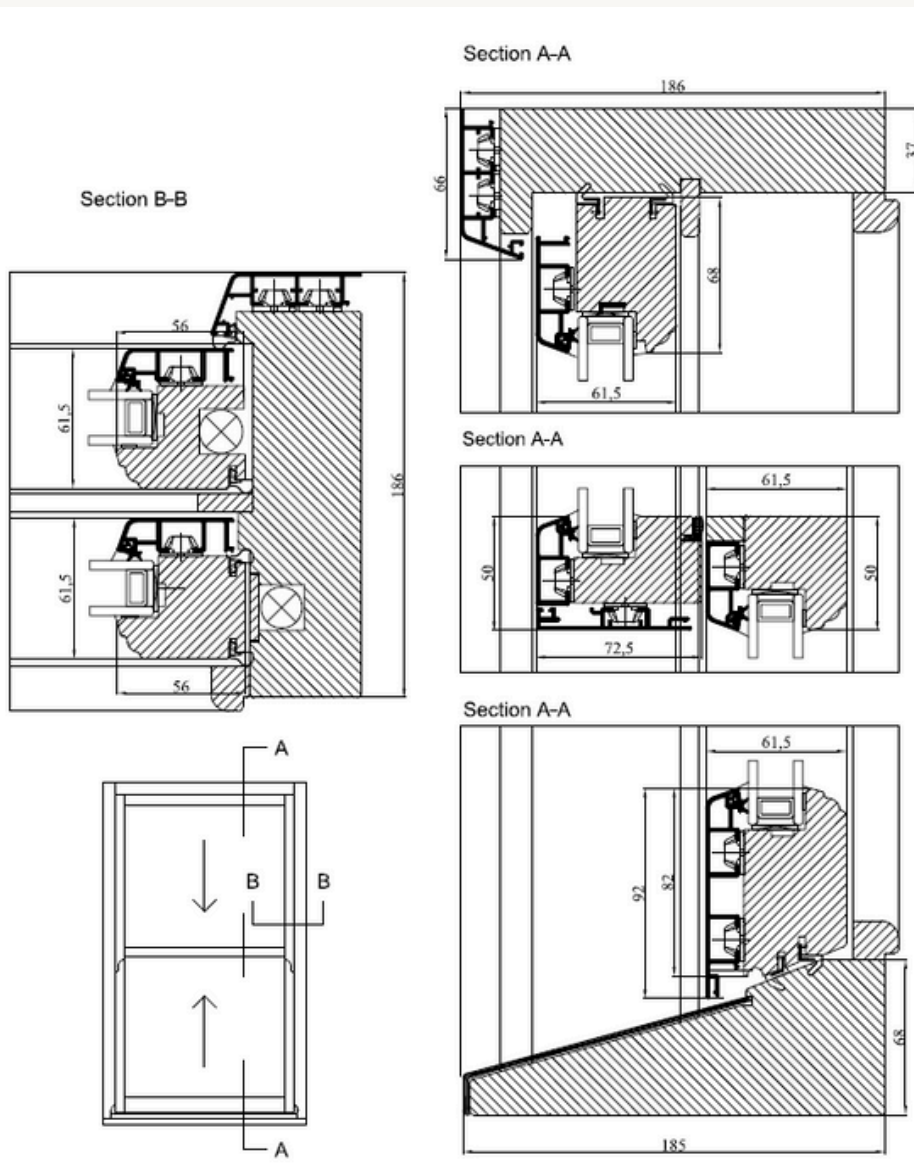

TRIPLE GLAZED

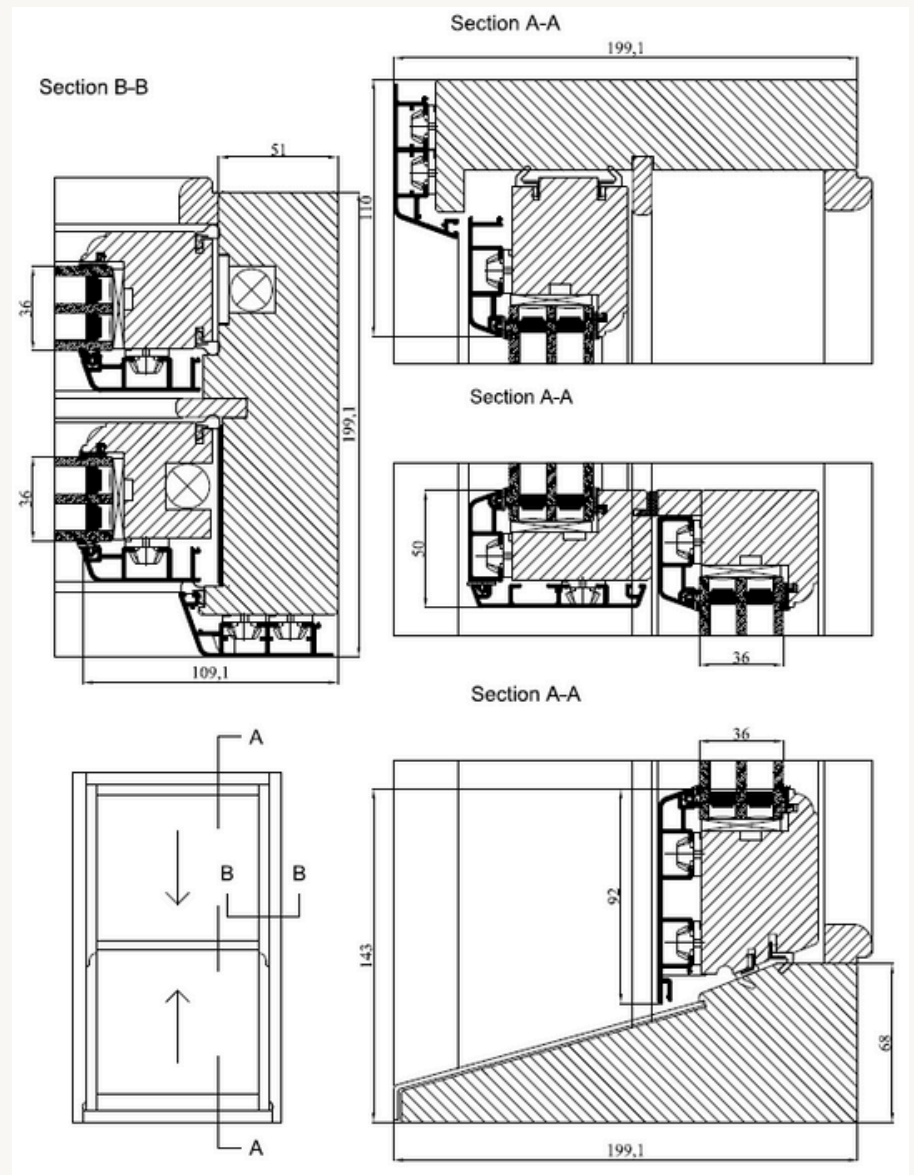

CASEMENT ALU-CLAD

APPLICATION THE
SAME AS FOR SLIDING
SASH ALU-CLAD
WINDOWS

AVAILABLE WITH
DOUBLE-GLASS UNITS
(79MM FRAME AND
56MM SASH) AND IN
OPTION WITH TRIPLE-
GLASS UNITS ON 91MM
FRAME AND 68MM
SASH



TECHNICAL DRAWINGS

DOUBLE GLAZED

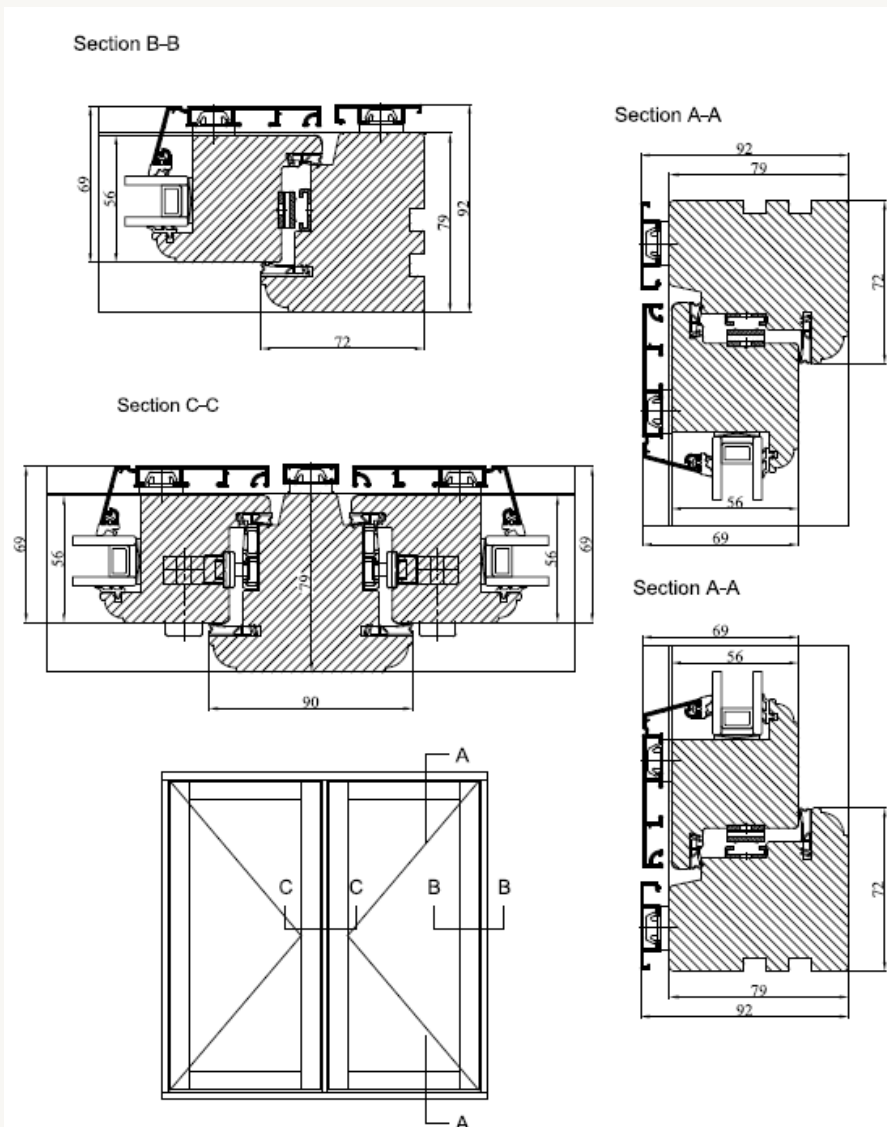

TRIPLE GLAZED

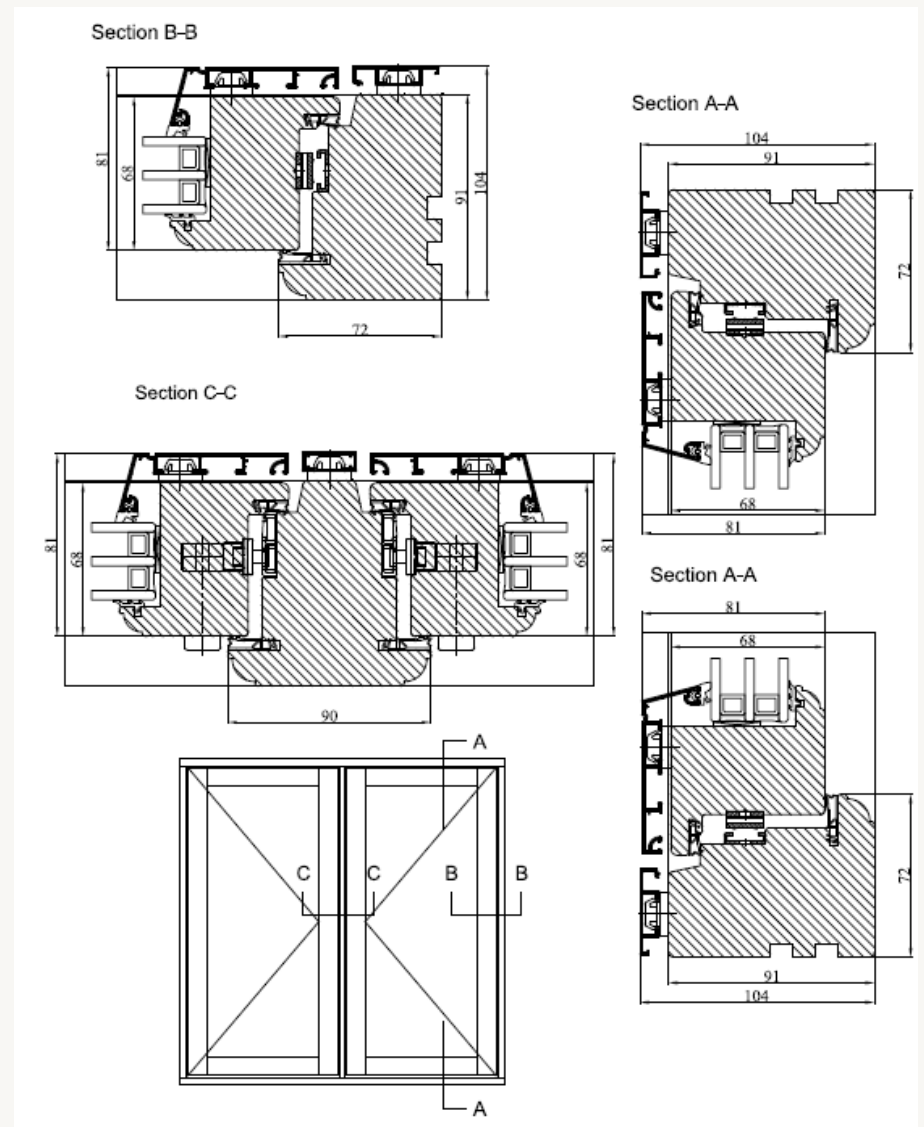

FLUSH DOOR ALU-CLAD

OPEN IN

OPEN OUT

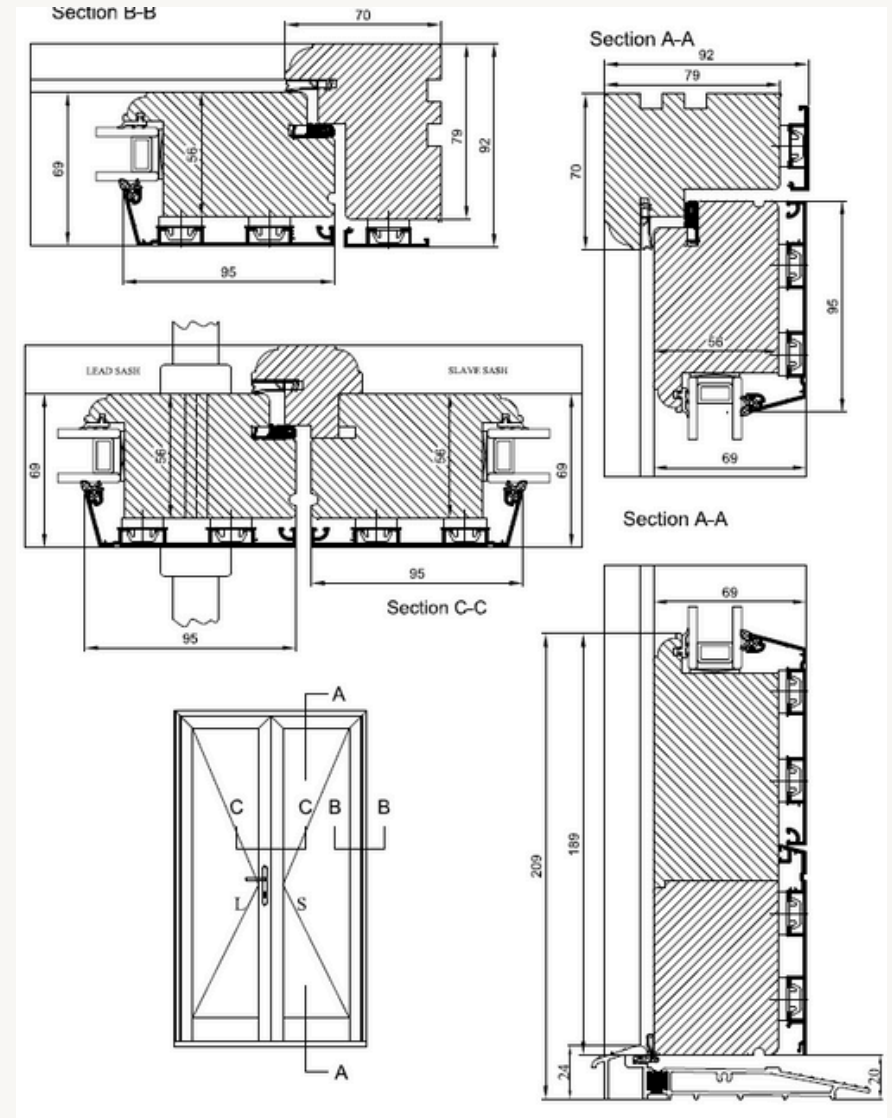
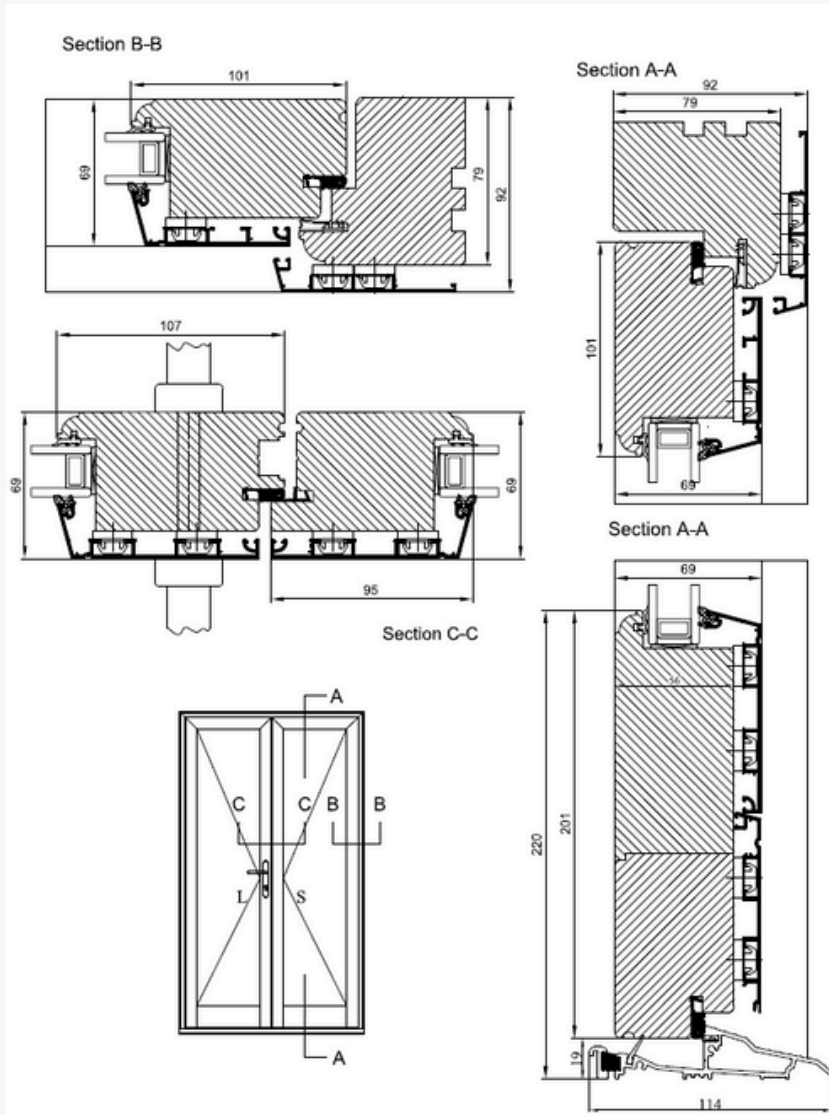

BI-FOLD DOOR ALU-CLAD

