



Preparation and Installation:

1. We recommend any Client to contact your local Council. It is Important to establish Councils requirements and expectations, as these can vary from one Council to another. Any pool will need to be registered with Council.

Likely your council may require either some or all of the following:

- Pool Fencing
- Backwash to be routed to a specific place, like sewer in some cases.
- Pool registration
- CPR and Safety Signage as required.
- In Some Areas a development Application will be required

This is not an Exhaustive List/guide, Your Council is the Authority. Any Guidance Provided by Duraplas or its representatives is not a replacement or substitute for the direct advice from any given authority.

2. Prepare the site and install the Aussie Plunge Pool shell in accordance with the Duraplas installation sheet (Refer Pages 7 and 8).
3. Install the skimmer box and return fitting as per the 'Leaf Skimmer Instruction Manual'. The skimmer hole is Cut by us at Factory, affixing the to this hole as per the instruction manual.
4. Install the Pool pump and sand filter by following the step-by-step instructions provided. You will require 19kg of Quartz sand with a particle size of 0.4 – 0.8. This sand is available from Bunnings or your local pool shop. Install the sand as per the instructions supplied.
The image overleaf will help show where to connect the hoses. **Ensure all hoses are free of debris prior to connection, stray debris (such as, gravel from the base) ingested into the system will not be covered under warranty.**
5. Ensure the required safety fences are installed correctly, any gates catches are child proof and operate correctly and that your pool complies with all your local council safety requirements. Ensure that your pool is registered as required and a CPR safety sign is fixed to the fence.
6. Fill your new Aussie Plunge Pool with water and check all hoses for leaks. Chlorinate your pool as required and regularly test the water. A test kit and chlorine are available from Bunnings or your local pool shop.
7. Enjoy many hours of fun and relaxation in your Aussie Plunge Pool.

POOL INLET, OUTLET AND LEAF SKIMMER PARTS

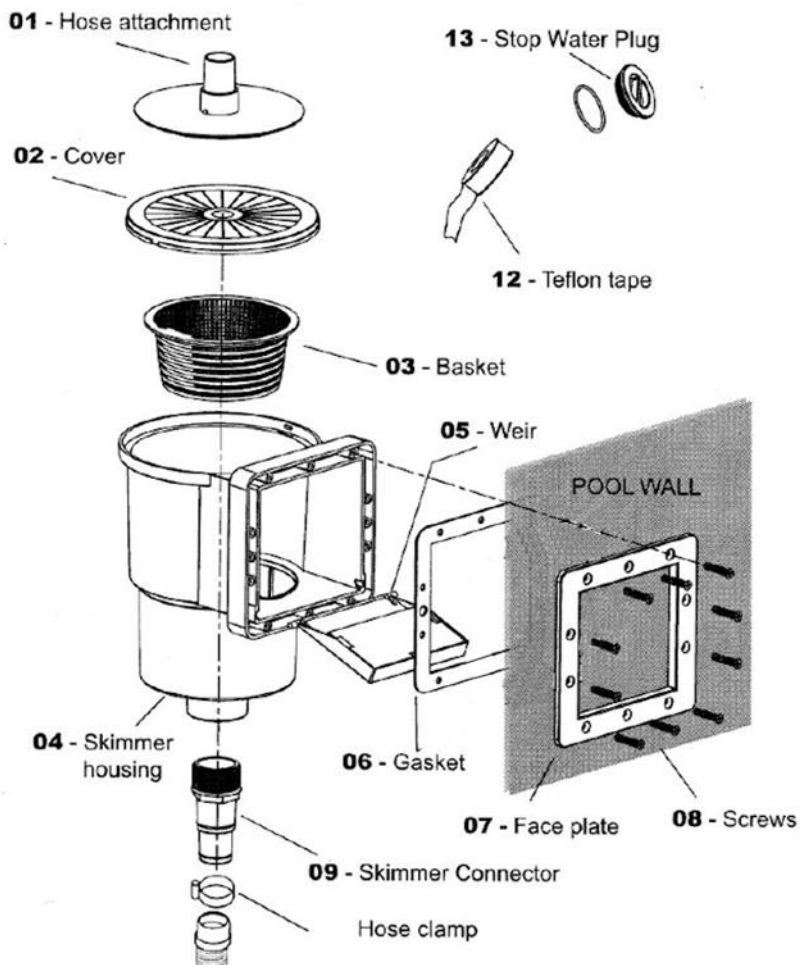

Item	Part No.	Description	Quantity
01	P6774	Hose Attachment	1
02	P6775	Cover	1
03	P6776	Basket	1
04	P6777	Skimmer Housing	1
05	P6778	Weir	1
06	P6779	Gasket	1
07	P6780	Face Plate Cover	1
08	P6781	Screw ST5.5x25	10
09	P6782	Skimmer Connector	1
10	P6763	Outlet Connector Kit	1
11	P6784	Inlet Connector Kit	1
12	P6785	Teflon Tape	1

Cut Out

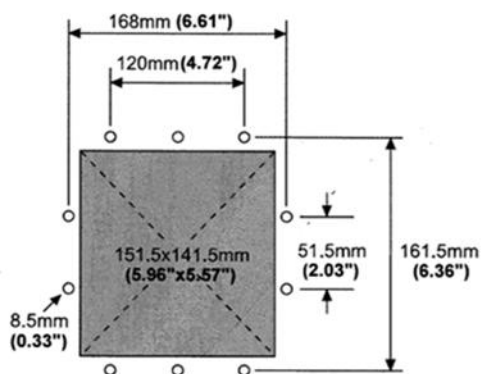

Leaf Skimmer Installation

1. Fill the pool with water between 3-6cm (1"-2") below the position of the Skimmer Hole. (See diagram 1)
2. From outside the pool wall, place the gasket (P6779) and skimmer housing (P6777) against the pool wall in line with the hole. (See diagram 4)
3. From inside the pool wall, place the gasket (P6779) and faceplate (P6780) against the pool wall in line with the hole. Push the screws carefully through the pool but do not securely tighten them until all the screws are in place. Ensure that the housing and inside faceplate are correctly aligned and tighten the screws into position but do not over tighten as you may damage the screws and / or the pool wall. Ensure that the gasket is not pinched or damaged. Do not create multiple holes as this will cause damage to the pool. Carefully trim off any protruding parts of the liner inside the connections after installation but do not trim off too much.
4. Screw the plug to the inside of the skimmer housing (P6777) to stop water flowing. (See diagram 5) When using the filtration system, please unscrew and remove the plug to allow water to flow to the filter pump.
5. Place the basket (P6776) into the skimmer housing (P6777) and fix the cover (P6775). Coat the Teflon tape (P6785) to the threading of the Skimmer Connector (P6782) and then connect it to the skimmer housing (P6777). (See diagram 4)
6. Clip the weir (P6778) to the front of the pool skimmer housing (P6777) if not already assembled.
7. Make sure the skimmer is sealed to the pool wall and no water is leaking.
8. Connect the filtration system to the pool. Follow the Sand Filter Manual for assembly requirements before operating.
9. The hose attachment (P6774) can be used to connect pool cleaning kits and Vacuums. (See diagram 6)
10. Finish off by checking and tightening all fittings but do not over tighten to avoid damage to the liner and pool wall.

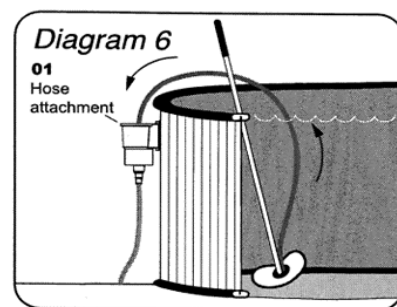
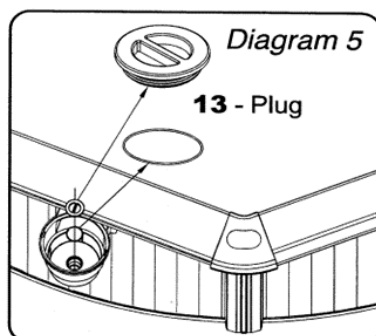
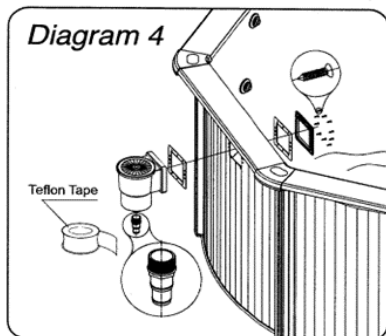

2

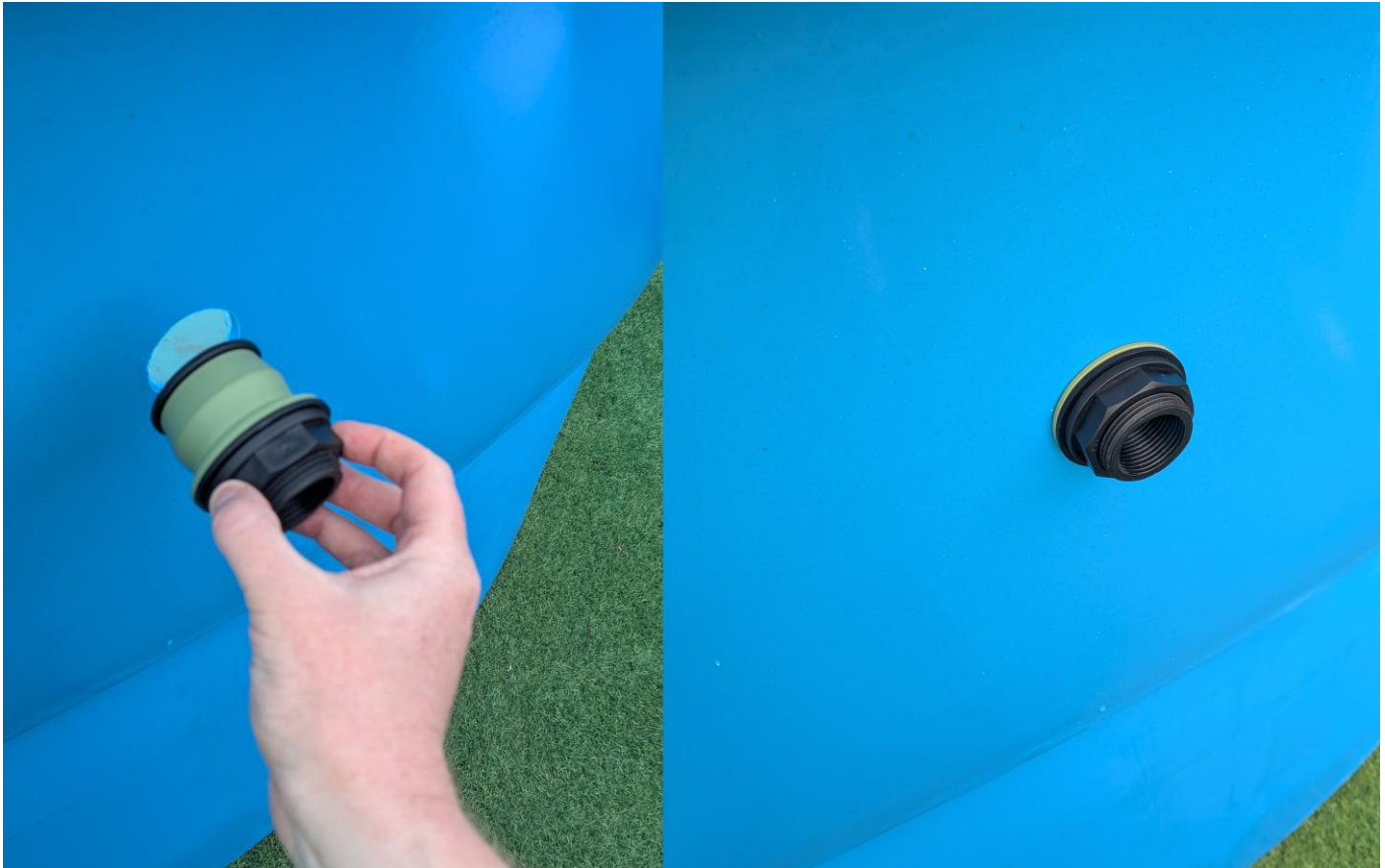

Thread the hose bard adaptor into the Plasson “Bucchi” fitting



The return line is now ready to be attached

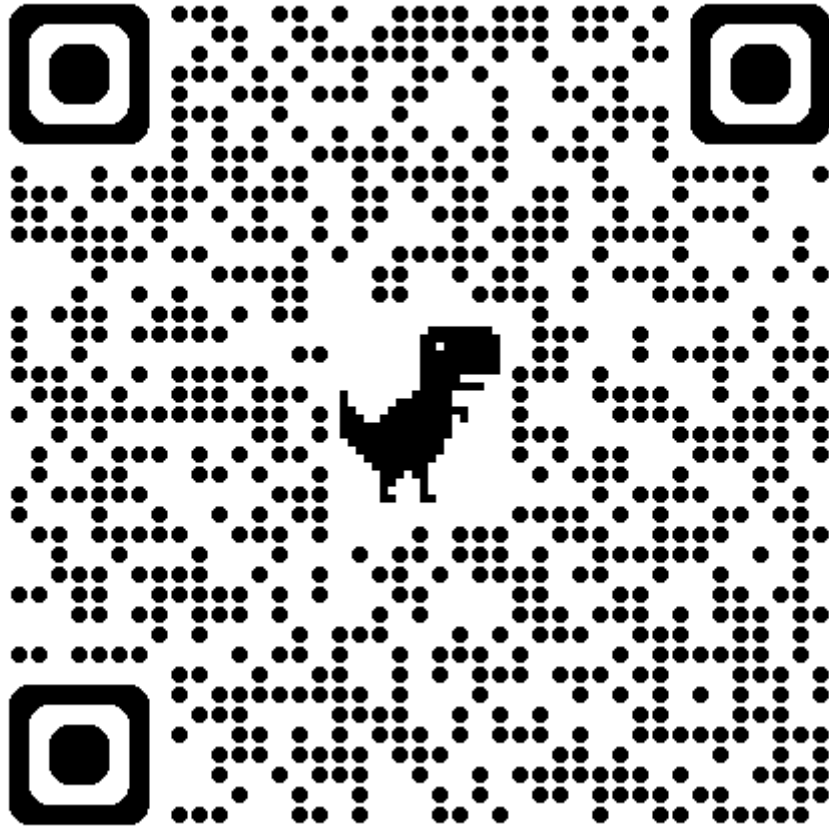

[Pool Pump and filter instructions click here](#) or use the QR above.

STANDARD PLUNGE & SPLASH POOL DETAILS

DWG. SCHEDULE

No.	TITLE
S1	COVER SHEET
S2	PLUNGE & SPLASH POOL 'ROUND' DETAILS
S3	PLUNGE POOL 'INFINITY 8' DETAILS

GENERAL

- These drawings shall be read in conjunction with all other Consultants drawings and specifications.
- Before proceeding with the works any discrepancies in the engineering drawings shall be referred for decision to the Engineer.
- Setting out dimensions and sizes of structural members or elements shall not be obtained by scaling the structural drawings.
- Any setting out dimensions shown on the engineering drawings shall be checked by the contractor before construction work commences.
- During construction the structure shall be maintained in a stable condition. Construction loads must not exceed the capacity of the structure at the time of loading. If in doubt ask the Engineer.
- All workmanship and materials shall be in accordance with the requirements of the current editions, including Amendments, of the relevant SAA Codes, except as varied by the Contract Documents and of the By-laws of the Local Government Authority.
- Permanent imposed and other loads (Dead and Live) for this project have been determined in accordance with AS/NZS 1170.1 - 2002.
- Wind loads for this project have been determined in accordance with AS/NZS 1170.2 - 2021.
- A Site Classification for this project was determined in accordance with AS2870 - 2011:

Class	Foundation soils
A	Most sand and rock sites with little or no ground movement from moisture changes
S	Slightly reactive clay sites with only slight ground movement from moisture changes
M	Moderately reactive clay or silt sites which can experience moderate ground movement from moisture changes
H	Highly reactive clay sites which can experience high ground movement from moisture changes
E	Extreme reactive sites which can experience extreme ground movement from moisture changes
A to P	Filed sites
P	Sites which include soft soils such as soft clay or silt or loose sand, landslip, mine subsidence, collapsing soils, soils subject to erosion, reactive sites subject to abnormal moisture conditions or sites which cannot be classified otherwise.
- The owner of the residence SHALL maintain the residence in accordance with:
 - The Home Owner Foundation Maintenance guide. Refer to SITE SOIL TEST REPORT.
 - The recommendation by C.S.I.R.O. information sheet titled "Foundation Maintenance and Footing Performance : A Homeowner's Guide."

EARTHWORKS

- Earthwork procedures should be carried out in a manner in accordance with AS 3798-1996 "Guidelines on Earthworks for Commercial and Residential Developments" and the guidelines by the Geotechnical Engineer. It is recommended that the earthwork contractor make himself familiar with site conditions.
- Fill requirements:
 - Imported fill should be a good quality material of low plasticity with a soaked CBR > 10% and a maximum aggregate size of 75mm.
 - All oversized material, including concrete debris, which may impede compaction must be removed.
 - Any fill containing building debris and/or organic matter must also be removed.
 - All fill must be compacted in 200mm to 300mm layers to achieve a minimum uniform field density of 95% relative to AS 1289.5.1.1 for cohesive fill material and minimum density index of 70 relative to E6.1 for granular non-cohesive fill material. The quality of compaction should be tested by NATA registered laboratory.
- Regardless whether compaction tests are carried out, provision shall be made to transfer footing loads to competent strata where indicated on plan and where required on site during footing excavation.
- All excavation work near the construction works that could cause undermining of piles/piers, footings, slabs, walls and structures shall be referred to and assessed for approval by the engineer prior to construction. Sheet piling or similar stabilisation methods may be required to stabilise the soils near the structure and shall be approved by the engineer prior to construction.

STRUCTURAL CONCRETE

- All workmanship and materials shall be in accordance with the requirements of the relevant current Australian Standard Codes (AS3600 & AS2870), Building By-laws and the Ordinances of the relevant Local Authority.
- Concrete class - Footings and Slab (due to exposure)
 - Slab on grounds on damp-proof membrane
 - Minimum N20MPa at 28 days
 - Footings in non-aggressive soil
 - Minimum N25mPa at 28 days
 - Footings in aggressive soil 1 km to 50 km from coastline
 - Minimum N32 MPa at 28 days
 - Footings in aggressive soil up to 1 km from coastline
 - Minimum N40 MPa at 28 days
- Concrete class - Slabs (due to abrasion)
 - Footpaths & residential driveways
 - Minimum N20 MPa at 28 days
 - Commercial/Industrial floor, no vehicular traffic
 - Minimum N25 MPa at 28 days
 - Light pneumatic tyred traffic, up to 3 t
 - Minimum N25 MPa at 28 days
 - Other pneumatic tyred traffic, over 3 t
 - Minimum N32 MPa at 28 days
 - Non-pneumatic tyred traffic
 - Minimum N40 MPa at 28 days
- Minimum cover to reinforcement:
 - 25 to upper face of internal slabs - 0 + 5mm
 - 45 for external exposure
 - 30 to a membrane in contact with ground
 - 40 to unprotected ground

STRUCTURAL REINFORCEMENT

- Minimum Laps and Splices for reinforcement
 - Slab fabric
 - 225 minimum overlap
 - Trench Mesh
 - 500 minimum lap in all footing beams at intersections as per details
 - Bars
 - 500 splices at all footing beam Laps at intersections as per details
- Reinforcement is presented diagrammatically and is not necessarily shown in true projection.
- Provide the Engineer 24 hours notice for inspection of reinforcement prior to pouring concrete. No concrete is to be poured without the approval of the Engineer.
- Splice in reinforcement shall be made only in the positions shown where lap length is not shown. It shall be sufficient to develop the full strength of the reinforcement.
- Welding of the reinforcement shall only be permitted with the prior approval of the Engineer.
- Reinforcement must not be continuous through construction joints.
- Placement of sufficient "studs" under main bottom reinforcement bar and top cross bar in slabs to support and allow adequate correct position during concreting (not greater than 900mm spacings).
- Supply and lay steel fabrics in flat sheets at splices. Fabric shall be lapped as specified or in accordance with AS33600.
- Reinforcement Symbols:
 - N Grade 500 MPa Deformed Bar
 - SL Grade 500 MPa Deformed Bar Mesh
 - A Grade 250 MPa Deformed Bar - Pool Construction
 - R Grade 250 MPa Plain Bar
- Provide 2N12 x 2000 long diagonal trimmers under top fabric at slab re-entrant corners as shown on plan.

Engineers Notation
All steelwork in marine and corrosive environments to be maintained and inspected for rust annually where visible.

<ul style="list-style-type: none"> VERIFY ALL DIMENSIONS, LEVELS AND EXISTING FEATURES ON SITE REFERRING ALL DISCREPANCIES TO THE ARCHITECT AND/OR ENGINEER PRIOR TO BEGINNING CONSTRUCTION. READ THE PLANS IN CONJUNCTION WITH THE SITE SOIL TEST REPORT. READ ALL DRAWINGS TOGETHER. SCALE OFF DRAWINGS AT OWN RISK. IF IN DOUBT ASK. 	GRAEME MOULSTON & Associates Engineering Pty. Ltd. ABN 36 151 969 783 FIE Aust CPEng 5590, RPEQ 4431 P.O. BOX 213 MUDGEERABA QLD 4213 Ph: (07) 5530 6214 Fx: (07) 5525 3774	Registered Professional Engineer GRAEME C. MOULSTON FIE Aust CPEng 5590 RPEQ 4431 Signature:..... Date: 15/04/2026	Job Title PLUNGE & SPLASH POOL For DURAPLAS 'AUSSIE PLUNGE POOLS'	Drawing Title COVER SHEET	DRAWN	DDP	15/04/2026	STD
					DESIGNED CHECKED	GCM	15/04/2026	
					Original sheet size = A3			S1 of 3
					SCALES: 10 20 30mm			A

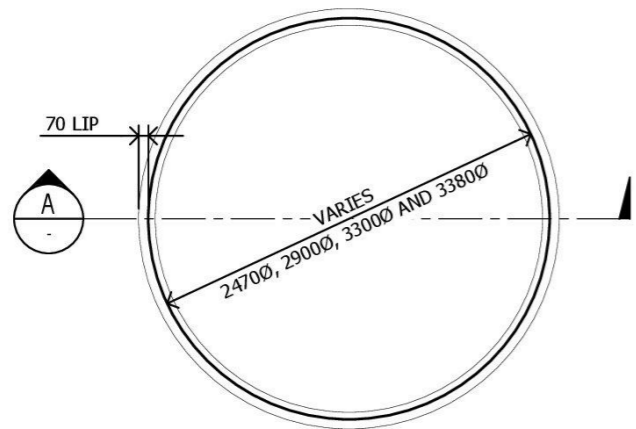

TYPICAL POLYETHYLENE POOL PLAN 1:50

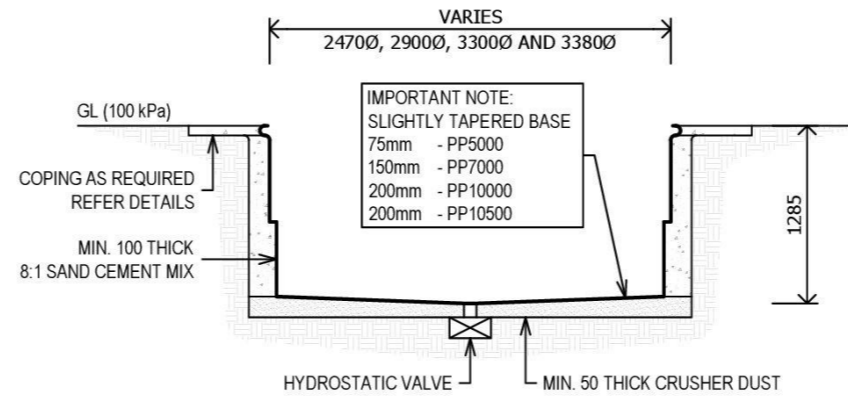

WHOLLY IN GROUND OPTION 1:50

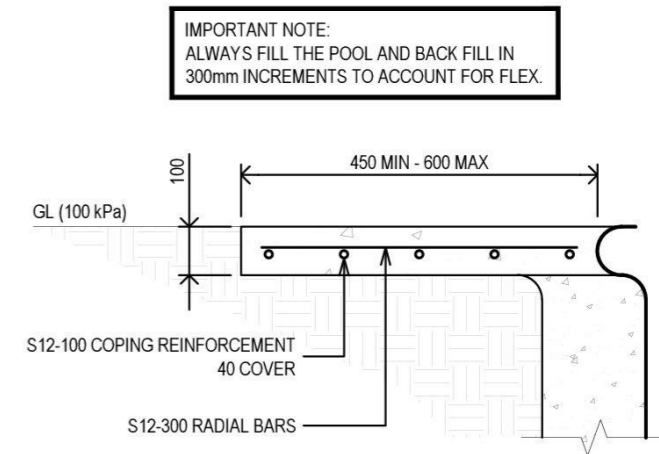

IN-GROUND COPING DETAIL 1:10

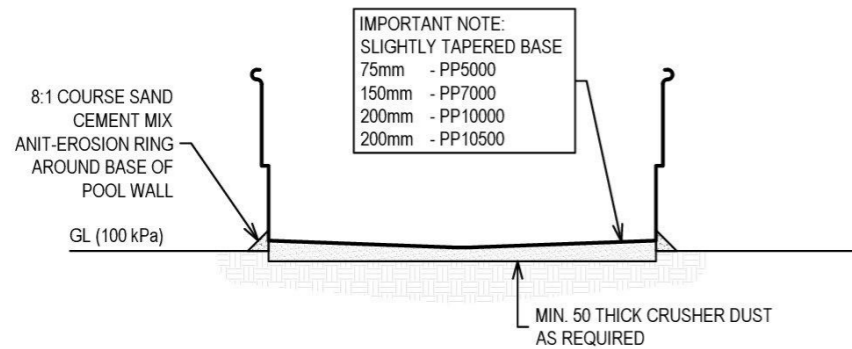

ABOVE GROUND - OPTION 1 1:50

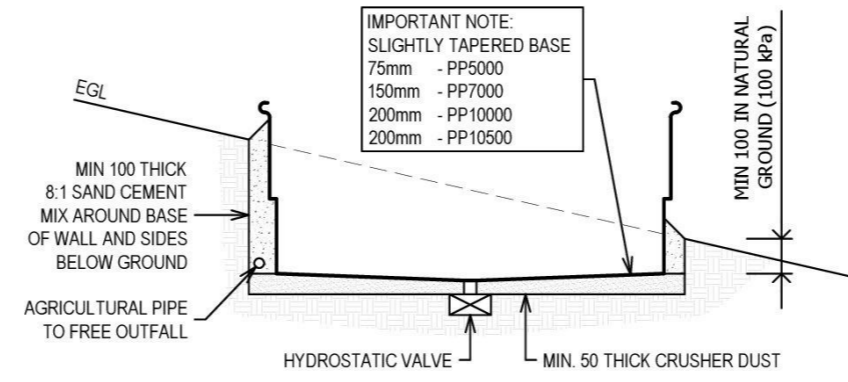

ABOVE GROUND - OPTION 2 1:50

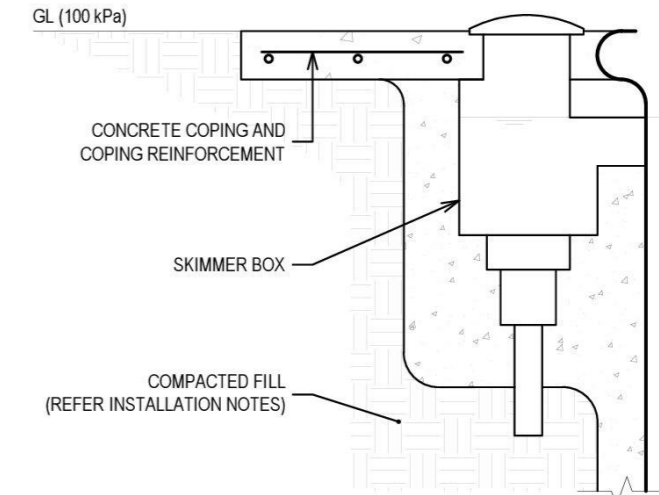

IN-GROUND SKIMMER BOX DETAIL 1:10

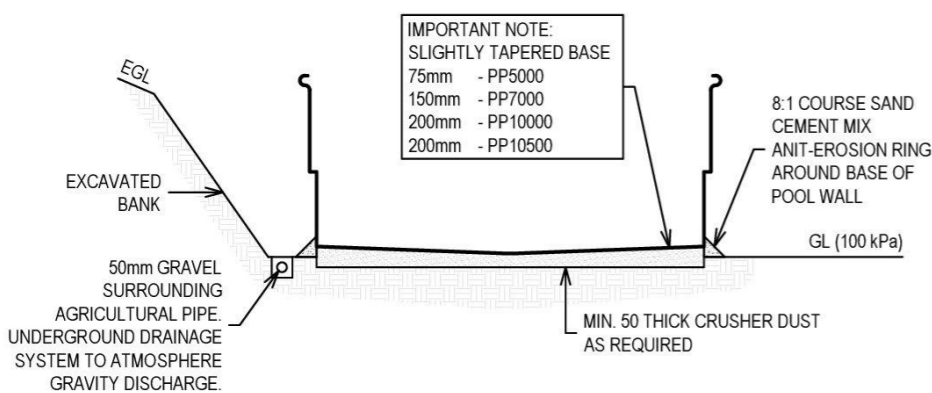

ABOVE GROUND - OPTION 3 1:50

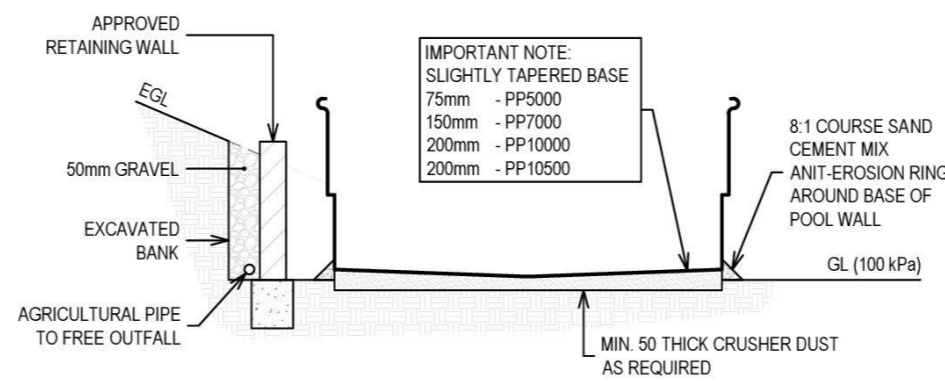

ABOVE GROUND - OPTION 4 1:50

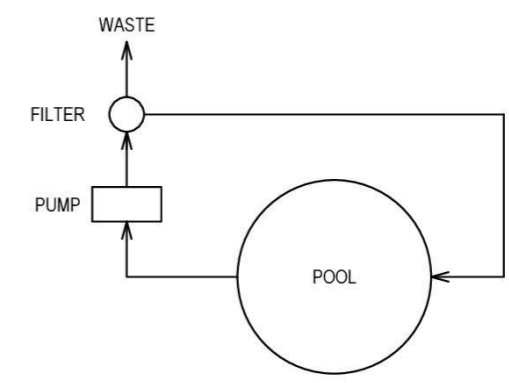

PLUMBING DIAGRAM N.T.S

- VERIFY ALL DIMENSIONS, LEVELS AND EXISTING FEATURES ON SITE REFERRING ALL DISCREPANCIES TO THE ARCHITECT AND/OR ENGINEER PRIOR TO BEGINNING CONSTRUCTION.
- READ THE PLANS IN CONJUNCTION WITH THE SITE SOIL TEST REPORT.
- READ ALL DRAWINGS TOGETHER.
- SCALE OFF DRAWINGS AT OWN RISK.
- IF IN DOUBT ASK.

GRAEME MOULSTON & Associates Engineering Pty. Ltd.
 ABN 36 151 969 783
 FIE AUST CPEng 5590, RPEQ 4431
 P.O. BOX 213 MUDGEERABA QLD 4213
 Ph: (07) 5530 6214 Fx: (07) 5525 3774

Registered Professional Engineer
GRAEME C. MOULSTON
 FIE Aust CPEng 5590 RPEQ 4431
 Signature:.....
 Date: **15/04/2026**

Job Title
PLUNGE & SPLASH POOL
 For DURAPLAS
'AUSSIE PLUNGE POOLS'

Drawing Title
PLUNGE & SPLASH POOL 'ROUND' DETAILS

DRAWN	DDP	15/04/2026	JOB NO. STD
DESIGNED	GCM	15/04/2026	
Original sheet size = A3			DRAWING NO. S2 of 3
10 20 30mm SCALES. -			AMEND A

PLUNGE POOL 'INFINITY 8' INSTALLATION INSTRUCTIONS:

- 1) EXCAVATE DESIRED LOCATION TO THE DIMENSIONS TO LEFT.
- 2) ENSURE THE BASE IS FIRM AND COMPACTED WELL.
- 3) SPREAD AND LEVEL AT LEAST 50mm THICK OF 'METAL' (CRUSHER) DUST ACROSS THE ENTIRE SITE.
- 4) USING A SMALL CRANE OR 4-6 ABLE BODIED PERSONS - PLACE THE POOL IN THE DESIRED POSITION.
- 5) POSITION THE STEP MOULDINGS HARD AGAINST THE POOL IN THE CENTRAL POSITION (ABOVE GROUND INSTALLATION ONLY).
- 6) PEG DOWN THE STEP MOULD USING THE 10 x GALVANISED PEGS PROVIDED.
- 7) FILL THE POOL WITH 300mm OF WATER.
- 8) FILL BOTH LEG MOULDS FULLY WITH WATER - FILL THROUGH THE TOP PLUG AND UNTIL IT OVERFLOWS.
- 9) REPLACE THE TOP PLUG AND SEAL THE LEG MOULDINGS.
- 10) CONNECT THE SKIMMER BOX AND PUMP FILTER (FOLLOW THE INSTRUCTION PROVIDED)
- 11) FILL THE POOL WITH WATER.
- 12) ENSURE A COMPLIANT POOL SAFETY FENCE IS INSTALLED.
- 13) ALLOW THE POOL TO SETTLE FOR 3-4 DAYS AND CHECK THE SITE FOR ANY MOVEMENT.
- 14) IF THE POOL IS UNDER THE NATURAL GROUND LEVEL, THEN POSITION AN AGRICULTURAL PIPE TO REMOVE ANY GROUND WATER BUILD UP.
- 15) BACKFILL THE SURROUNDING OF THE POOL WITH 8:1 SAND CEMENT MIX - ENSURE THAT THIS IS DONE 300mm STAGES. AFTER EACH STAGE WET THE FILL BEFORE MOVING TO THE NEXT LEVEL OF FILL.
- 16) ONCE THE BACKFILLING IS COMPLETE POSITION PAVERS OR A CONCRETE COPING AROUND THE POOL AS PER DETAILS ABOVE.
- 17) ENSURE ALL LOCAL COUNCIL REGISTRATION REQUIREMENTS ARE MET AND ALWAYS MAINTAIN THE SAFETY FENCING SO THAT ANY CHILDREN CANNOT ENTER THE POOL AREA WITHOUT ADULT SUPERVISION.

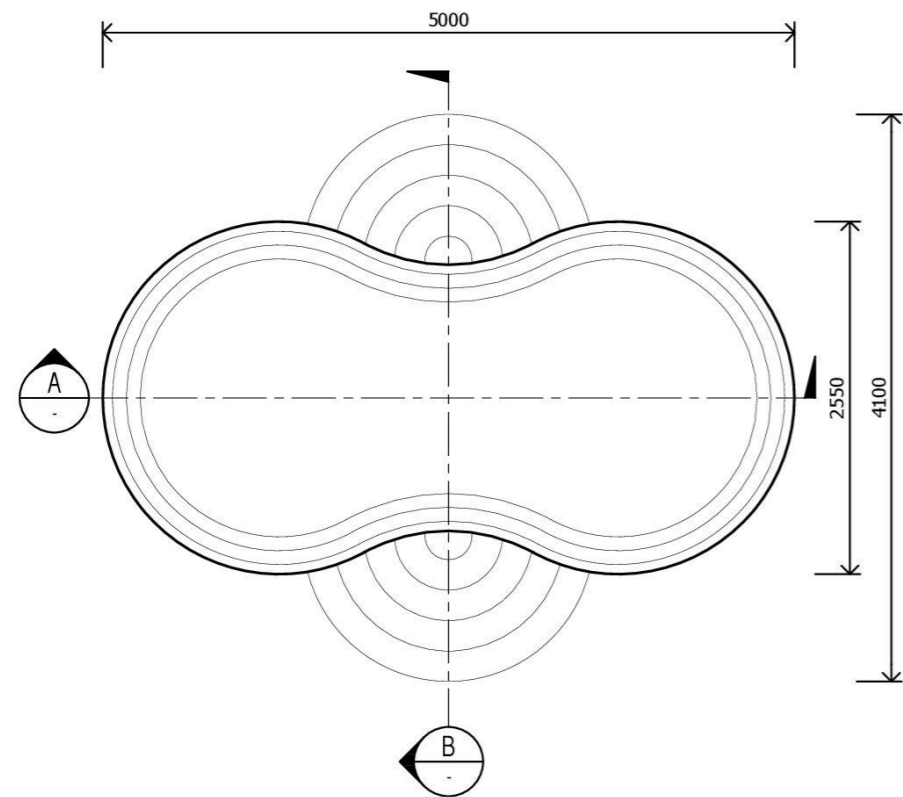

TYPICAL POLYETHYLENE POOL PLAN 1:50
'INFINITY 8' DESIGN

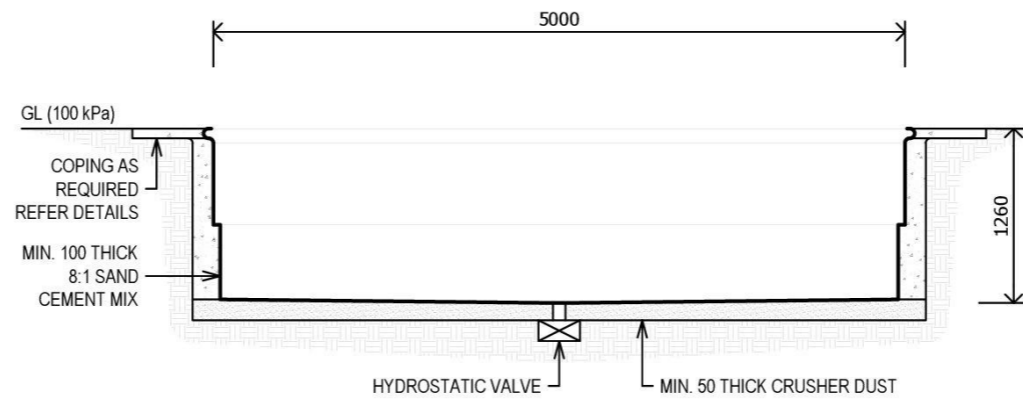

A WHOLLY IN GROUND OPTION 1:50

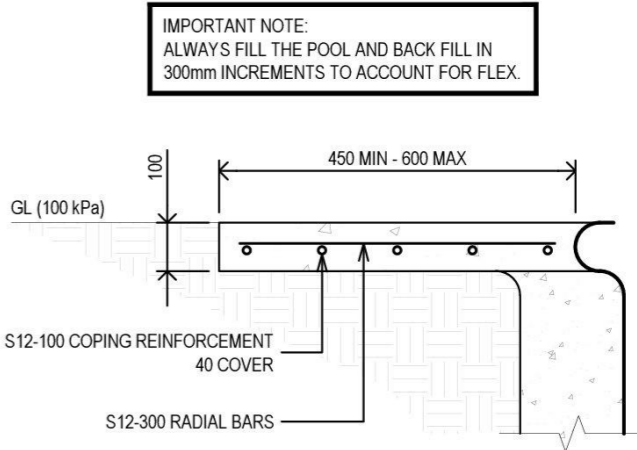

IN-GROUND COPING DETAIL 1:10

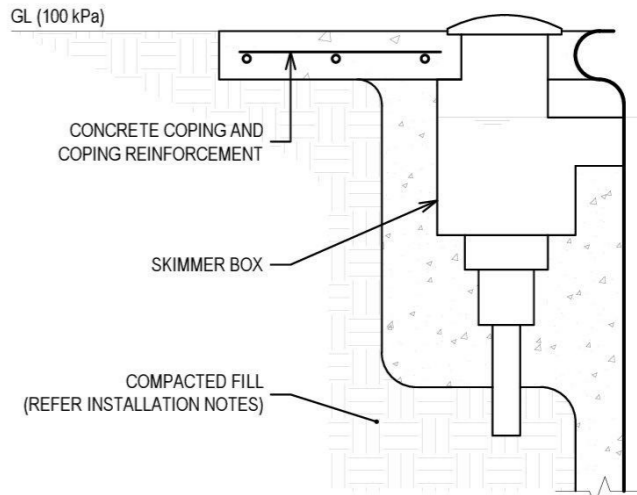

IN-GROUND SKIMMER BOX DETAIL 1:10

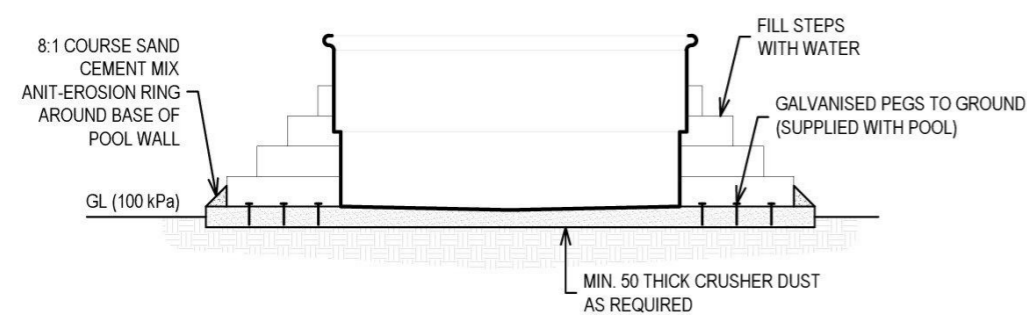

B ABOVE GROUND - OPTION 1 1:50

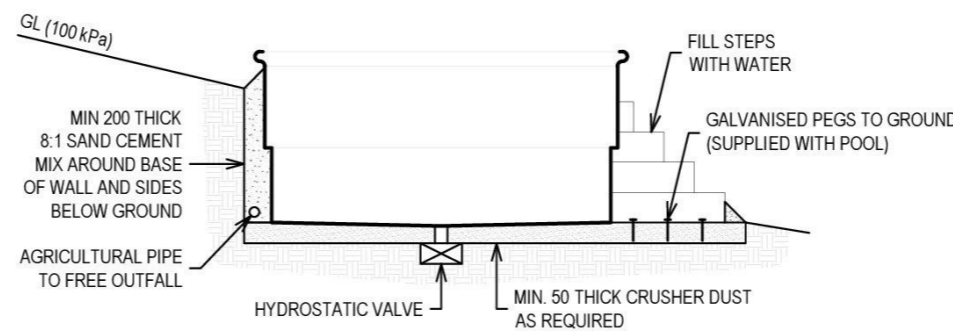

B ABOVE GROUND - OPTION 2 1:50

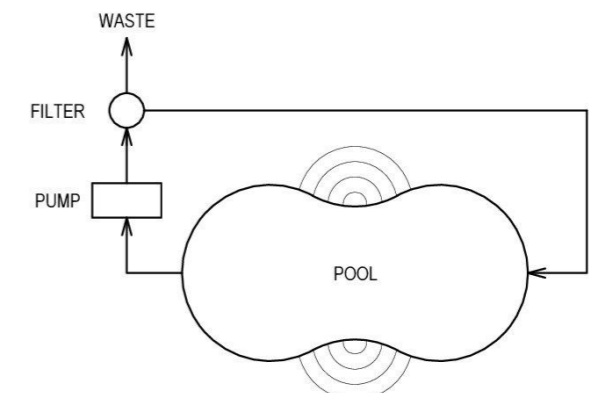

PLUMBING DIAGRAM N.T.S

- VERIFY ALL DIMENSIONS, LEVELS AND EXISTING FEATURES ON SITE REFERRING ALL DISCREPANCIES TO THE ARCHITECT AND/OR ENGINEER PRIOR TO BEGINNING CONSTRUCTION.
- READ THE PLANS IN CONJUNCTION WITH THE SITE SOIL TEST REPORT.
- READ ALL DRAWINGS TOGETHER.
- SCALE OFF DRAWINGS AT OWN RISK.
- IF IN DOUBT ASK.

GRAEME MOULSTON & Associates Engineering Pty. Ltd.
 ABN 36 151 969 783
 FIE Aust CPEng 5590, RPEQ 4431
 P.O. BOX 213 MUDGEERABA QLD 4213
 Ph: (07) 5530 6214 Fx: (07) 5525 3774

Registered Professional Engineer
GRAEME C. MOULSTON
 FIE Aust CPEng 5590 RPEQ 4431
 Signature:.....
 Date: **15/04/2026**

Job Title
PLUNGE & SPLASH POOL
 For DURAPLAS
'AUSSIE PLUNGE POOLS'

Drawing Title
PLUNGE POOL
'INFINITY 8'
DETAILS

DRAWN	DDP	15/04/2026	JOB NO. STD
DESIGNED	GCM	15/04/2026	
Original sheet size = A3			DRAWING NO. S3 of 3
10	20	30mm	
SCALES.			AMEND A

Optional Hydrostatic Valve Assembly

For Inground Installations, an optional hydrostatic valve is recommended.

Installed at time of pool installation onsite – 58mm hole saw.



Each state-based compliance form must be issued with the pool site address noted. Please contact your sales agent to obtain the copy applicable to your project location.