

Relative, vacuum- and differential pressure transmitter

-1 ... +1 mbar / 0 ... 0.3 – 50 mbar



Huba Control

FEINE MESSIDEEN FÜR DRUCK UND STRÖMUNG
FOR FINE PRESSURE AND FLOW MEASUREMENT
LA FINESSE DES MESURES DE PRESSION ET DE DÉBIT

Technical overview

The differential pressure transmitters of the Type 699 series incorporate a proven ceramic fulcrum lever technology. They deliver adjusted and temperature-compensated sensor signals, available as standard voltage or current outputs. They are ideal for registering low air flow in air conditioning systems and for the measurement of fine pressures in laboratory, environmental and clean-room applications.

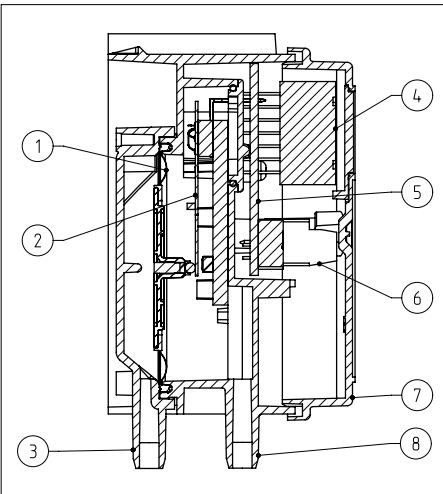

Legend to cross-section drawing

- 1 Diaphragm
- 2 Sensor element
- 3 P1 Pressure connection
(higher pressure / minor Vacuum)
- 4 LCD-Display (option)
- 5 Amplified electronics
- 6 Connection terminals
- 7 Cover
- 8 P2 Pressure connection
(higher pressure / major Vacuum)

The distinct advantages

- Compact construction
- Fast, easy mounting.
Housing incorporates integral bracket for wall or ceiling mounting. Snap-on cover with a single screw
- Available with LCD display = additional configurations all version according to order code selection table
- Filter function
- Adjustable measurement range
- Switchable output signals
- Switchable response curve (linear or root-extracted)
- Zero point resettable (reset button)
- Full scale adjustable
- Attractive price / performance ratio
- Application at over and low pressure range possible

Medium

Air and neutral gases

Pressure range

±0.5 mbar
±1 mbar
0 ... 1 – 50 mbar

Tolerable overload on one side

Application at over pressure range
100 mbar auf P1, 4 mbar auf P2

Application at low pressure range
-4 mbar auf P1, -100 mbar auf P2

Rupture pressure

2 x overload at ambient temperature
1.5 x overload at 70 °C

Setting range

Zero point resettable by reset button

Full scale adjustable by DIP-Switch and additional individual adjustable with Turbopot

Materials in contact with medium

Housing: Polycarbonate PC
Diaphragm: Silicone
Sensor: Al₂O₃ (96%) / glass

Temperature

Medium and ambient 0 ... +70 °C
Storage -10 ... +70 °C
No condensation

Output

3-wire
0 ... 10 V 13.5... 33 VDC / 24 VAC ±15%
0 ... 20 mA 13.5... 33 VDC / 24 VAC ±15%
4 ... 20 mA 13.5... 33 VDC / 24 VAC ±15%

2-wire
4 ... 20 mA 8.0 ... 33 VDC

Power supply

Additional adjustable by software
(with LCD-Display only)

0 ... 5 V 6.5... 33 VDC / 24 VAC ±15%

Load

3-wire
0 ... 10 V > 10 kOhm
0 ... 20 mA < 500 Ohm
4 ... 20 mA < 500 Ohm

2-wire
4 ... 20 mA $< \frac{\text{supply voltage} - 8 \text{ V}}{0.02 \text{ A}}$ [Ohm]

Current consumption

At nominal pressure

3-wire
0 ... 10 V < 10 mA
0 ... 20 mA < 30 mA
4 ... 20 mA < 30 mA

2-wire
4 ... 20 mA 20 mA

Backlight LCD-Display 30 mA

Dynamic response

Suitable for dynamic measurements
Response time < 20 ms
Load cycle < 10 Hz

Filter

Filter response time switchable by
0.2 / 1 / 5 / 20 seconds

Electrical connection

Screw terminals for wire and stranded conductors up to 1.5 mm², cable gland with built-in strain relief PG11

Polarity reversal protection

Short circuit proof and protected against polarity reversal. Each connection is protected against crossover up to max. supply voltage.

Protection standard

Without cover IP 00
With cover IP 54 or IP 65

Pressure connections

Connection pipe Ø 6.2 mm

Installation arrangement

Recommended and factory adjustment:
Vertical, with pressure connections downwards

Mounting

Mounting bracket (integrated in case)

Display

LCD display
doublespaced - per 8 digit alphanumeric
(3-wire with backlight)

Adjustability

Optional version self configurable several parameter (see order code selection table)

Tests / Admissions

UL
CE conform

Weight

With display approx. 100 g
Without display approx. 90 g

Packaging

Single packaging in cardboard

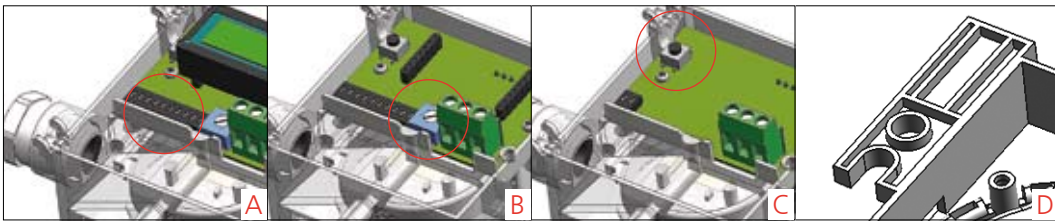

Version

- A - Tenfold DIP-Switch
- B - Turbo-Potentiometer
- C - Zero point reset
- D - Housing with built-in fixing brackets

Dimensions in mm

Electrical connections

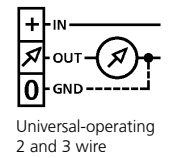
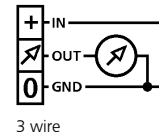
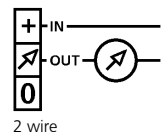
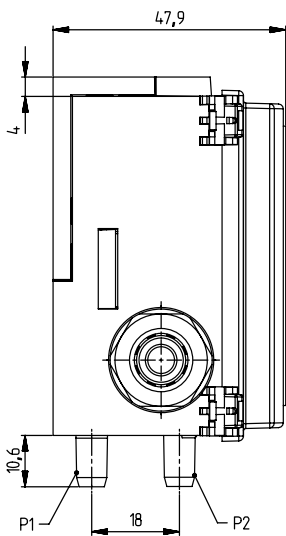
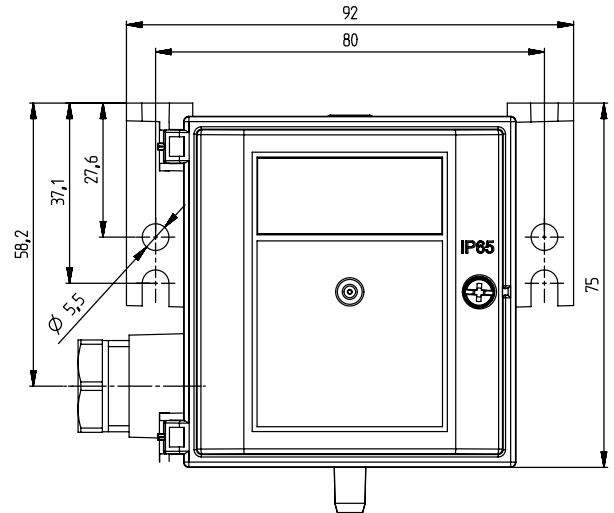
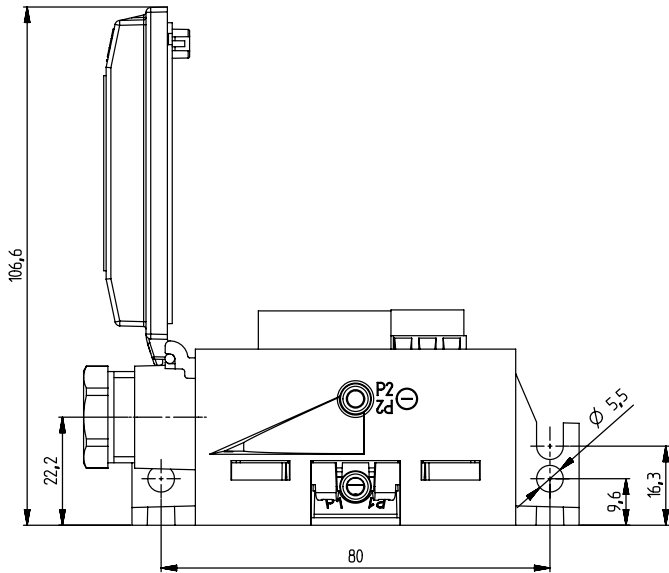

Accessories

Set 1

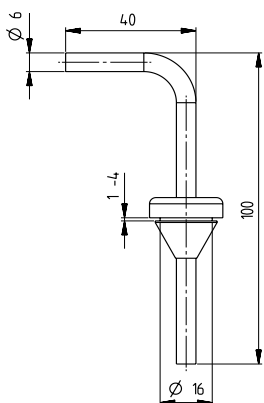

Set 2

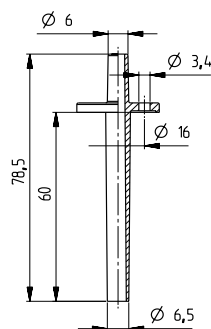

DIN-rail mounting adapter

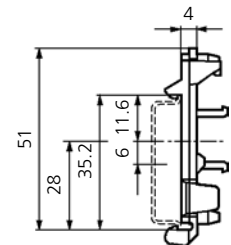
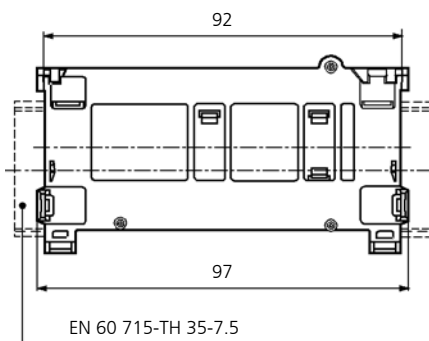

Electromagnetic compatibility

CE conformity according EN 61326-2-3.

Headquarters
Huba Control AG
Industriestrasse 17
CH-5436 Würenlos
Telefon ++41 (0) 56 436 82 00
Telefax ++41 (0) 56 436 82 82
info.ch@hubacontrol.com

Huba Control AG
Niederlassung Deutschland
Schlattgrabenstrasse 24
72141 Walddorfhäslach
Telefon ++49 (0) 7127 23 93-00
Telefax ++49 (0) 7127 23 93-20
info.de@hubacontrol.com

Huba Control SA
Succursale France
Technopôle Forbach-Sud
57602 Forbach Cedex
Téléphone ++33 (0) 387 847 300
Télécopieur ++33 (0) 387 847 301
info.fr@hubacontrol.com

Huba Control AG
Vestiging Nederland
Hamseweg 20A
3828 AD Hoogland
Telefoon ++31 (0) 33 433 03 66
Telefax ++31 (0) 33 433 03 77
info.nl@hubacontrol.com

Huba Control AG
Branch Office United Kingdom
Unit 3 Network Point, Range Road
Witney Oxfordshire OX29 0YD
Phone ++44 (0) 1993 776 667
Fax ++44 (0) 1993 776 671
info.uk@hubacontrol.com

Huba Control AG
Rep. Office Singapore
Rep Office Singapore, No. 16 Ayer Rajah Crescent Witney
#06-06B Tempco Technominium, SG-139965 Singapore
Phone ++65 (0) 61 004 822
Fax ++44 (0) 63 994 822
info.sg@hubacontrol.com

Huba Control AG
Rep. Office China
Rep Office Shanghai, CBC Building
49A Wuyi Road, CN-Shanghai 200050
Phone ++86 (0) 21 511 808 21
Fax ++86 (0) 21 515 520 99
info.cn@hubacontrol.com

www.hubacontrol.com

 **Huba Control**

FEINE MESSIDEEN FÜR DRUCK UND STRÖMUNG
FOR FINE PRESSURE AND FLOW MEASUREMENT
LA FINESSE DES MESURES DE PRESSION ET DE DEBIT