



Differential pressure transmitter

Huba Control

Relative and differential pressure transmitter

Type 699M

The pressure transmitter 699M is used primarily for the monitoring of air and neutral gasses. The unit is optionally available with one or two differential pressure sensors, which allows the observation of differential pressure or volumetric flow at two individual points in the system. This makes the 699M ideally suited for a multitude of tasks in the HVAC industry.

The 699M communicates via Modbus® RTU and features two universal inputs in addition to two analog outputs. The linking of further sensors and control of actuators offers the option of using the unit as a decentralized node for existing controllers, extending in- and outputs, and lowering installation costs.

The sensors utilized by the unit are based on the unique and well-proven ceramic strain-gauge beam technology developed by Huba Control AG.



Pressure range

0 ... 500 – 7000 Pa

- + High accuracy and long-term stability via ceramic strain-gauge technology
- + Modbus® RTU interface
- + Available with one or two differential pressure sensor units
- + Up to two universal inputs for 0 ... 10 V or passive temperature elements
- + Two 0 ... 10 V analog outputs
- + Simple installation, reduced wiring effort through decentralized node

Technical overview

Pressure range					
Relative and differential		0 ... 500 – 7000 Pa			
Measuring variables		Pa, psi, mmHG, mmH ₂ O			
Operating conditions					
Medium		Air and neutral gases (not condensing)			
Temperature	Medium	0 ... +70 °C			
	Ambient	-25 ... +50 °C			
	Storage	-30 ... +70 °C			
	No condensation				
Tolerable overload on one side (short-term)		P+ = 10'000 Pa / P- = 400 Pa			
Rupture pressure	Ambient temperature	20'000 Pa			
	70 °C	15'000 Pa			
Materials in contact with medium					
Sensor		Ceramic Al ₂ O ₃ (96%)			
Diaphragm		Silicone			
Housing		Polycarbonat PC / Polyamide (PA)			
Electrical overview					
Power consumption		< 2 VA			
Power supply		24 VAC/DC ±15%			
Voltage outputs		2x 0 ... 10 V			
Universal inputs		2x 0 ... 10 V / PT1000 / LG-Ni1000 / NTC10K / Ni1000			
Response time		< 1 s			
Polarity reversal protection	Short circuit proof and protected against polarity reversal. Each connection is protected against crossover up to max. supply voltage.				
Wire length	signal wiring	max. 50 m			
	Modbus® wiring	max. 100 m			
Protection standard		Protection class			
IP 54		III			
Modbus®					
Address range		1-247 (40 = default if DIP = 0)			
Baudrate		9600 - 57'600			
Format		Modbus® RTU			
Line termination		selectable via DIP-Switch			
Hardware		RS485			
Standard configuration	selectable via DIP-Switch	9600E1 (9600 baud rate, 1 stop bit, even parity)			
Interface					
Push button	Zero point reset, reset on factory setting				
DIP switch	Modbus® adress, baud rate, parity and scheduling				
LED	Status indication (red, yellow, green, blue)				
Electrical connection					
Screw terminals for wire and stranded conductors up to 2.5 mm ²					
2 x cable bushing \varnothing 15 for cable \varnothing 3 - 6 mm					
2 x cable bushing \varnothing 20 for cable \varnothing 5 - 10 mm					
Analogue outputs A01, A02					
Accuracy	0 ... 10 VDC	0 V	±66 mV		
		5 V	±95 mV		
		10 V	±124 mV		
Resolution		< 11 mV			
Output current		max. 1 mA			
Analogue inputs AI1, AI2		Accuracy	Resolution	TK/B_{25/85}	
Accuracy	configured as PT1000	-50 ... +150 °C	±0.5 K	0.1 K	3850 ppm/K
	configured as LG-Ni1000	-50 ... +150 °C	±0.5 K	0.1 K	5000 ppm/K
		-50 ... -26 °C	±1.0 K	0.2 K	3979 ppm/K
	configured as NTC10K	-25 ... +99 °C	±0.5 K	0.1 K	3979 ppm/K
		+100 ... +150 °C	±3.0 K	0.5 K	3979 ppm/K
	configured as Ni1000	-50 ... +150 °C	±0.5 K	0.1 K	6180 ppm/K
		0 V	±5 mV	< 5 mV	-
	configured as 0 ... 10 VDC	5 V	±25 mV	< 5 mV	-
10 V		±50 mV	< 5 mV	-	
Input resistance		min. 100 k Ω			
Flow calculation					
Permitted K-Factor range		0 ... 1500			
Calculation Formula		$Q = k \cdot \sqrt{\Delta P}$			
Measuring variables		l/s, m ³ /h, m ³ /s			
Pressure connection					
Connection pipe		\varnothing 6.2 mm (for pipe inside \varnothing 5 mm)			
Mounting instructions					
Installation arrangement		Factory calibration: Vertical with pressure connections downwards			
Mounting		Mounting bracket (integrated in case)			
Tests / Admissions					
UL		ANSI/UL 60730-1			
CE-conformity		acc. 2014/30/EU applied standard EN 60730-1			
EAC					
Weight					
		~ 250 g			
Packaging					
		Single packaging in cardboard			
		Multiple packaging (20 pcs.)			

Accuracy

Parameter	Unit	0 ... 500 Pa	0 ... 1250 Pa	0 ... 2500 Pa	0 ... 5500 Pa	0 ... 7000 Pa
Overall accuracy at +20 °C	% fs	< ±1.0	< ±0.5	< ±0.5	< ±0.6	< ±0.7
Overall accuracy at 0 ... +50 °C	% fs	< ±2.0	< ±1.0	< ±1.0	< ±0.8	< ±0.8
Resolution	% fs	< 0.1	< 0.1	< 0.1	< 0.1	< 0.1
Long term stability acc. DIN EN 60770	% fs	< ±1.0	< ±1.0	< ±1.0	< ±1.0	< ±1.0

Test conditions:
25 °C, 45% rh, power supply 24 VDC

Order code selection table		1	2	3	4	5	6	7	8	9
		699M.								
Pressure range P1 ¹⁾	0 ... 500 Pa	0	5							
	0 ... 1250 Pa	1	2							
	0 ... 2500 Pa	2	5							
	0 ... 5500 Pa	5	5							
	0 ... 7000 Pa	7	0							
Pressure range P2 ¹⁾	without pressure connection P2			0	0					
	0 ... 500 Pa			0	5					
	0 ... 1250 Pa			1	2					
	0 ... 2500 Pa			2	5					
	0 ... 5500 Pa			5	5					
0 ... 7000 Pa			7	0						
Communication	Modbus® RTU						M			
Analogue input	2 x universal inputs 0 ... 10 VDC, temperature (PT1000 / LG-Ni1000 / NTC10K / NI1000)							2		
Analogue output	2 x 0 ... 10 V								2	
Electrical connection	4 x cable bushing for cable									4
Pressure connection	Connection pipe Ø 6.2 mm									0
	Connection pipe Ø 6.2 mm									1

Accessories (supplied loose)

Order number

Connection kit for vent duct (metal), 90° angled, 2pcs (Fig. 1)	including tube 2 m long	104312
Connection kit for vent duct (plastic), straight, 2 pcs (Fig. 2)	including tube 2 m long	100064

Dimensions in mm / Electrical connections

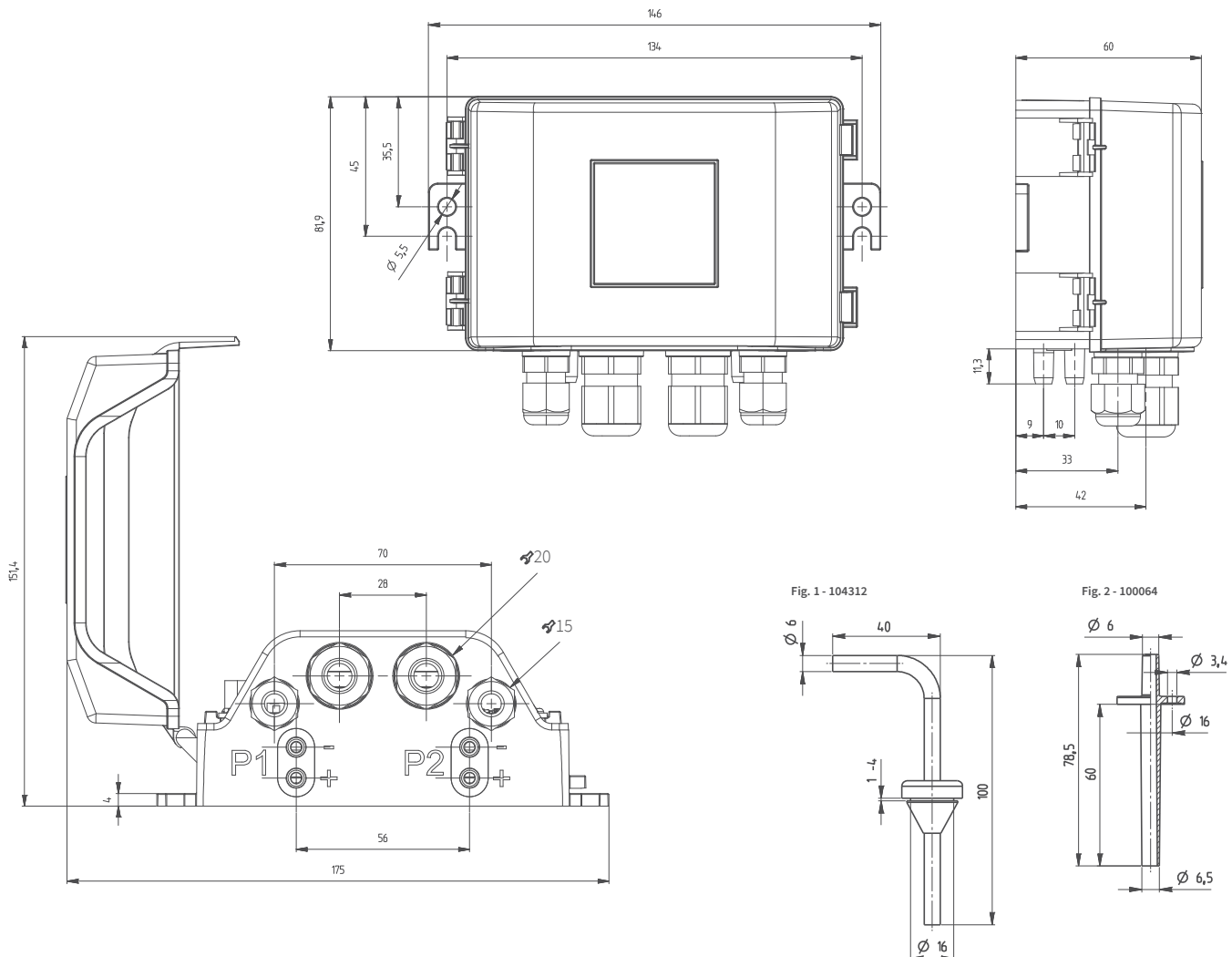

¹⁾ max. 10000 Pa (over pressure on one side)

Setting and connection elements

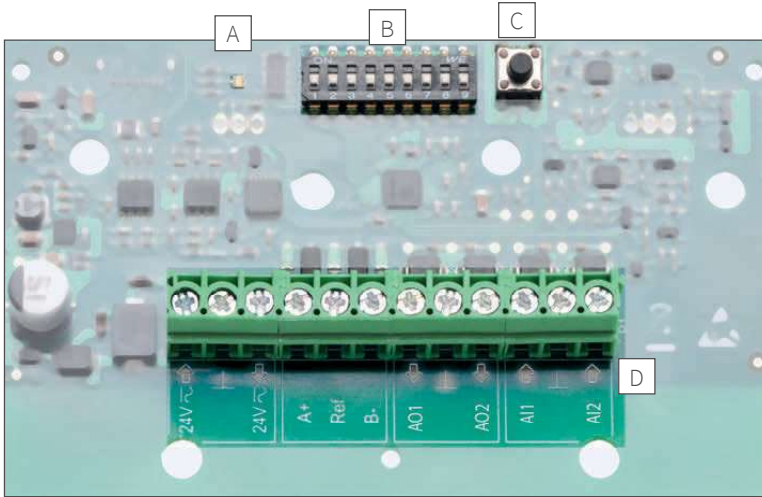

A	Status LED
B	DIP switch
C	Push button
24 V ~ →	Power supply 24 VAC/DC
⊥	GND
24 V ~ ←	Power supply external devices 24 VAC/DC
A+	Modbus® communication +
Ref	Common
B-	Modbus® communication -
AO1 ←	Analogue output 1
⊥	GND
AO2 ←	Analogue output 2
AI1 →	Analogue input 1
⊥	GND
AI2 →	Analogue input 2

Huba Control AG

Headquarters Schweiz
Industriestrasse 17
CH-5436 Würenlos
Telefon +41 56 436 82 00
Fax +41 56 436 82 82
info.ch@hubacontrol.com

Huba Control AG

Niederlassung Deutschland
Schlattgrabenstrasse 24
D-72141 Walddorfhäslach
Telefon +49 7127 2393 00
Fax +49 7127 2393 20
info.de@hubacontrol.com

Huba Control AG

Vestiging Nederland
Hamseweg 20A
NL-3828 AD-Hoogland
Telefoon +31 33 433 03 66
Telefax +31 33 433 03 77
info.nl@hubacontrol.com

Huba Control SA

Succursale France
Rue Lavoisier
Technopôle Forbach-Sud
F-57602 Forbach Cedex
Téléphone +33 3 87 84 73 00
Télécopieur +33 3 87 84 73 01
info.fr@hubacontrol.com

Huba Control AG

Branch Office United Kingdom
Unit 13 Berkshire House, County Park
Business Centre, Shrivenham Road
Swindon, Wiltshire SN1 2NR
Phone +44 1993 77 66 67
Fax +44 1993 77 66 71
info.uk@hubacontrol.com

www.hubacontrol.com

